

English

# OWNER'S MANUAL

X-Rays Spectro 70X



**DABI ATLANTE**

**PAGE INTENTIONALLY LEFT BLANK**

### PRESENTATION OF THE MANUAL

**Technical name:** Dental X-Ray Equipment

**Trade name:** X-rays

**Brand:** Dabi Atlante

**Commercial Models:**

- Spectro 70X Coluna Móvel
- Spectro 70X+ Coluna Móvel
- Spectro 70X Pantográfico Coluna Móvel
- Spectro 70X Parede
- Spectro 70X Pantográfico Parede

**ANVISA registration nº:** 10069210087

**Technical Manager:** Daniel R. de Camargo

CREA-SP: 5062199650



Alliage S/A Indústrias Médico Odontológica  
Rodovia Abrão Assed, Km 53 + 450m - CEP 14097-500  
Ribeirão Preto - SP - Brasil  
Tel: +55 (16) 3512-1212

**REF**

77000001203 - Rev.: 10 - November/22

Document originally written in Portuguese.

### **TRADEMARKS**

All terms mentioned in this manual that are known trademarks, registered trademarks or service marks have been appropriately labeled as such. Other products, services or terms that are mentioned in this manual may be trademarks, commercial trademarks or service marks of their respective owners. Alliage S/A makes no claims regarding these trademarks. The use of a term in this manual should not be considered to influence the validity of any trademark, commercial trademark or service mark.

Dabi Atlante is a registered trademark of Alliage S/A.

Copyright © 2021 Alliage S/A. All rights reserved.

The performance characteristics provided in this manual are for reference only and should not be considered as guaranteed specifications.

## SUMMARY

<b>01</b>	<b>GENERAL INFORMATION</b>	<b>07</b>
1.1.	DEAR CUSTOMER	08
1.2.	INDICATION FOR USE	08
1.3.	CONTRAINDICATION	08
1.4.	SIMBOLOGY	08
<b>02</b>	<b>WARNINGS, CAUTIONS AND RECOMMENDATIONS</b>	<b>12</b>
<b>03</b>	<b>SYSTEM OVERVIEW</b>	<b>19</b>
3.1.	PRODUCT DESCRIPTION	20
3.2.	APPLICATION SPECIFICATION	20
3.2.1.	Operating principles	20
3.2.2.	Significant physical characteristics	20
3.2.3.	User profile	21
3.3.	MAIN COMPONENTS OF THE PRODUCT	22
3.4.	SETS AND ACCESSORIES	23
3.5.	PARTS APPLIED	23
3.6.	USER INTERFACE	24
3.6.1.	Interface Display	24
3.6.2.	Control Panel	24
3.7.	POSITIONING OF LABELS	25
<b>04</b>	<b>OPERATION</b>	<b>26</b>
4.1.	INITIAL PREPARATION	27
4.2.	POSITIONING	27
4.2.1.	Preparing the patient	27
4.2.2.	Positioning the patient	28
4.2.3.	Radiographic techniques	28
4.3.	EXPOSURE TIME	30
4.3.1.	Exposure time selection	30
4.3.2.	Reference parameters for exposure	30
4.4.	EXPOSURE	31
4.4.1.	Local trigger	31
4.4.2.	Stop firing	31
4.5.	RECOMMENDATIONS FOR EXAMS	32
<b>05</b>	<b>DOSE INFORMATION</b>	<b>35</b>
5.1.	DOSE CALCULATION	36
5.2.	LEAKAGE RADIATION	38
5.3.	DIFFUSION RADIATION	39
<b>06</b>	<b>CLEANING AND DISINFECTION</b>	<b>41</b>
<b>07</b>	<b>PROBLEM DIAGNOSIS</b>	<b>43</b>
7.1.	ERROR MESSAGE	44
7.2.	TROUBLESHOOTING	44
<b>08</b>	<b>QUALITY DIAGNOSIS</b>	<b>45</b>
8.1.	QUALITY CONTROL	46
8.1.1.	Accuracy	46
8.1.2.	Image quality	47
8.1.3.	Dose measurement	47

## SUMMARY

<b>09</b>	<b>INSPECTION AND MAINTENANCE</b>	<b>48</b>
9.1.	PERIODIC INSPECTION	49
9.2.	PREVENTIVE MAINTENANCE	50
9.3.	CORRECTIVE MAINTENANCE	50
9.4.	ALLIAGE AUTHORIZED SERVICE NETWORK	50
<b>10</b>	<b>WARRANTY</b>	<b>51</b>
<b>11</b>	<b>SPECIFICATIONS AND TECHNICAL CHARACTERISTICS</b>	<b>53</b>
11.1.	EQUIPMENT CLASSIFICATION	54
11.2.	DEVICE INFORMATION	54
11.3.	ENVIRONMENTAL CONDITIONS	55
11.4.	RADIOLOGICAL INFORMATION	55
11.5.	X-RAY GENERATOR	56
11.6.	X-RAY TUBE	57
11.7.	STANDARDS AND REGULATIONS	60
11.8.	DIMENSIONAL	61
<b>12</b>	<b>ELECTROMAGNETIC COMPATIBILITY (EMC)</b>	<b>66</b>
12.1.	ORIENTATION AND DECLARATION FOR ELECTROMAGNETIC EMISSIONS	67
12.2.	ORIENTATION AND DECLARATION FOR ELECTROMAGNETIC IMMUNITY	68

## GENERAL INFORMATION

## 1. GENERAL INFORMATION

### 1.1. DEAR CUSTOMER

Congratulations on your excellent choice. By purchasing equipment with ALLIAGE quality, you can be assured of the acquisition of technology products compatible with the best in the world in its class. This manual provides you with a general presentation of your equipment, describing important details that may guide you in your correct use, as well as in solving small problems that may occur. No additional training is required beyond your own reading. This manual should be read in full and kept for future reference.

### 1.2. INDICATION FOR USE

The Dental X-ray Apparatus is intended for the acquisition of radiological images of oral anatomy, including teeth, maxillofacial areas, oral and bone structures, and it is for exclusive dental use, and should be handled by qualified and qualified health professionals.

### 1.3. CONTRAINDICATION

This equipment is contraindicated for people undergoing radioiodine treatment for thyroid cancer.

### 1.4. SIMBOLOGY

The following symbols are used both throughout this manual and in the product. Make sure that you fully understand each symbol and follow the accompanying instructions.



Fragile, handle with care



Parts applied type B



Protect from rain



Catalog number



This side up



Model name



Protect from sunlight



Model number





Maximum stacking



Serial number

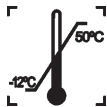

Temperature limit



Indicates that the product has undergone an evaluation, and that standards or regulations developed for the product category have been observed in its design/manufacture/placing on the market.



Manufacturing Date



Manufacturer



Recyclable



Indicates that the product should be taken to a special garbage collection location at the end of its useful life. Applies to both the device and accessories.



On Position



Off Position



Protection Grounding



Alternating Current



Phase 1 conductor



**Biphasic configuration:**  
Phase 2 conductor  
**Single-phase configuration:**  
Neutral Phase



Focal Point Position



Electrostatic Sensitive Devices (ESD)



Check instruction manual



**Mandatory action**



**Warning**  
Ionizing Radiation



**General warning**



**Warning**  
High Voltage



**Warning**  
Hand Crushing



Attention



Presence or Potential Presence of Ionizing Radiation / Physiological Effect



Trigger



**Restart**  
Changes the time of x-ray emission to zero.



Ionizing radiation emission



**Ready**  
Indicates that the equipment is ready to operate



Time Selector (increase)



Time Selector (decrease)



Adult Profile



Child Profile



Mandibular Front



Maxillary Molar



Canine Mandibular



Molar Mandibular



Maxillary Canine



Interproximal



Film Receiver



Digital Sensor Receiver







Phosphor Plate Receiver

## **WARNINGS, CAUTIONS AND RECOMMENDATIONS**

## 2.WARNINGS, CAUTIONS AND RECOMMENDATIONS

### General warnings



	<p>Please read and understand all instructions contained in these instructions for use before installing or operating this equipment.</p>
	<p>Only use the equipment in perfect conditions and protect yourself, patients and third parties from any hazards.</p>
	<p>This equipment should be installed and operated by personnel familiar with the necessary precautions, to avoid excessive exposure to both primary and secondary radiation.</p>
	<p>The Dental X-Ray Equipment has four different interactions with the user, which are:</p> <ul style="list-style-type: none"><li>- Identification and safety label: located on the back of the equipment;</li><li>- LCD panel/LEDs: located on the front of the remote control of the equipment;</li><li>- Membrane keyboard: located on the front of the equipment trigger control;</li><li>- Local exposure button: located on the front of the equipment trigger control.</li></ul>

### During transport

The equipment must be transported and stored as instructed:

- Handle care to prevent falls and impacts.
- The packing arrows should be pointing upwards.
- Do not stack above the quantity indicated on the package.
- Protect against sunlight, moisture, water and dust.
- Observe the temperature, pressure and relative humidity limits.

### During the installation of the equipment

	<p>The installation instructions can be found in the service manual, accessible only to authorized technicians.</p>
	<p>The equipment is configured for network voltage during the installation of the equipment only by the authorized technician. This is a technical procedure that cannot be performed by the user.</p>



The equipment must be properly affixed according to the service manual.



To avoid the risk of electric shock, this equipment should be connected only to a grounding power network for protection.



For single-phase installation, the fuse must be replaced by the supplied metal pin to remove the fuse from the neutral conductor.









Before turning on the equipment, make sure it is connected at the correct voltage.

- The equipment should only be installed by authorized technical assistants.
- The recommendations of the service manual should be followed for the mandatory existence of protection grounding.
- The equipment must not be subjected to excessive vibration or shock (including during transport and handling).
- Install the equipment in a place where it will not be in contact with moisture, water, plants and animals.
- Install the equipment in a location where it will not be damaged by pressure, temperature, humidity, direct sunlight, dust, airs or corrosive products.
- The equipment must be properly affixed according to the service manual.
- This equipment is not designed for use in the presence of vapors from flammable anesthetic mixtures or nitrous oxide.
- Place any other external devices at least 1.5 meters away from the X-ray unit, so that the patient cannot touch it while it is being x-rayed.
- The recommendations related to EMC in this manual should be followed. Communications equipment and RF-generating sources can affect the operation of the equipment.
- Equipment may cause radio interference or disrupt the operation of nearby equipment, and it is necessary to take mitigating measures such as reorientation, relocation of equipment or shielding of the place.
- The installation in Brazil must meet the requirements of RDC No. 330 of December 20, 2019 and IN No. 95 of May 27, 2021 of the National Health Surveillance Agency and its updates.

### Before using the equipment

To help ensure proper hygiene and protect against infectious diseases, prior to first use, the equipment should be cleaned and disinfected by following the instructions contained in this manual.

### When using the equipment

	No part of the equipment should touch the patient during its use.
	Do not remove the covers. High internal voltage. Danger of electric shock.
	Mobile equipment should not be tilted more than 5°. Risk of tipping over.
	Take care when operating the equipment, moving parts can hold and/or crush
	The equipment is equipped with a safety device for overvoltage in the power supply of the equipment, not allowing the firing when the power network exceeds the specified limit.
	The equipment is equipped with a safety device for undervoltage in the power supply of the equipment, not allowing the firing when the power network is below the specified limit.

- Under no circumstances the patient can operate the unit.
- The equipment should be operated only by qualified health professionals including knowledge of precautions against excessive radiation exposure.
- To operate the unit, operating personnel must:
  - Read and understand the user manual;
  - Be familiar with the structure and fundamental functions of this unit;
  - Be familiar with the emergency situation protocols of this equipment;
  - Be able to recognize irregularities in the operation of the unit and implement appropriate measures when necessary.
  - During movement, hold at the indicated location on the equipment.
- The equipment is designed according to electromagnetic compatibility standards, but in very extreme conditions, it may cause interference with other equipment. Do not use this equipment in conjunction with other devices that are very sensitive to interference or with devices that create high electromagnetic disturbances.
- The equipment is not recommended for the display of cartilage structures and soft tissue exposure.
- Depending on local regulations, during an exposure, the operator must position himself at least 3 meters away from the X-ray unit to reduce the amount of ionizing radiation absorbed while

## Owner's Manual

---

maintaining eye contact with the patient and the unit throughout the exposure.

- In case of risk to the patient, cancel the exposure immediately by releasing the exposure button.
- If this product is exposed to water, moisture or foreign substances, turn it off immediately and contact an Alliage Authorized Service Center.
- In case of damage or defect, do not use the equipment and contact an Alliage Authorized Service Center.
- Do not use the unit if any of its compartments or parts are damaged, loose, or removed. Contact an Alliage Authorized Service Center and request repair or replacement of any damaged, loose, or removed enclosures or parts of the unit before using the unit again.
- Do not touch the unit or use it if it is being repaired or if the cabinets on the unit have been removed.
- Do not open or remove any of the cabinets from the unit. No internal part can be repairable by the user.
- In case of fall or impact causing it to break, be careful when handling them, there may be sharp parts.
- Do not contact accessible connectors while in contact with the patient.



The Spectro 70X Coluna Móvel and Spectro 70X+ Coluna Móvel models must be transported with the overlapping arms moving forward according to the illustration below.

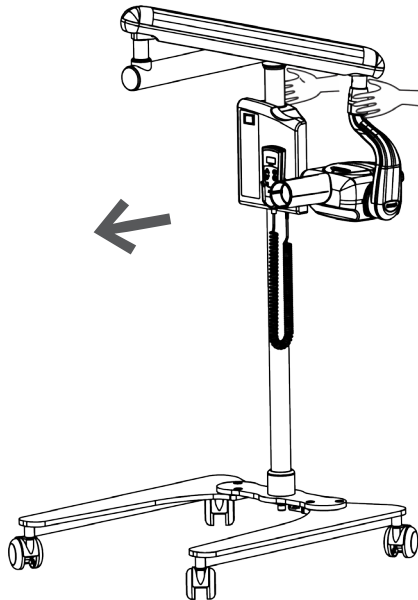



## Radiation protection



Protective measures should be taken against ionizing radiation and residual radiation to avoid side effects to users and operators. Access to equipment should be restricted in accordance with the country's local radiation protection standards to avoid unnecessary exposure.



The apron and lead thyroid collar do not accompany the equipment.

- Exposure to X-rays can cause damage to cells in the human body.
- Radiation protection equipment should be used to reduce radiation exposure to the patient, specifically for pediatric and pregnant patients.
- The patient and operator should wear lead apron and thyroid collar during exposures.
- The use of X-ray equipment in pregnant women is not recommended without medical authorization.
- A patient with a cardiac pacemaker or an implantable cardioverter defibrillator (DCI) should consult their manufacturer before performing an exposure to confirm that the X-ray unit will not interfere with its operation.
- Exposure to X-rays can cause damage to cells in the human body. Thus, radiation protection equipment should be used to reduce radiation exposure to the patient, especially for pediatric patients. It is recommended to wear an apron or bismuth or lead vest during exposures.
- No person should remain in the room during an exposure unless the patient needs to be restrained. In this case, a third person must be properly protected against the emission of ionizing radiation.
- During an exposure, the operator must position himself:
  - As far away from the focus of the X-ray generator as possible, maintaining a minimum distance of 3m, or
  - Behind a physical barrier, to reduce as much as possible the amount of ionizing radiation absorbed.

## Prevention against cross-contamination



Appropriate cleaning and disinfection measures should be taken to avoid cross-contamination between patients, users and others.

- For each new patient, perform the cleaning and disinfection procedures according to the instructions contained in this manual.

## After use / operation of the equipment

- Turn off the equipment if not in use for too long.
- All parties that have had contact with the patient, operator or third parties or body fluids such as saliva and blood, should be cleaned and disinfected for each new patient to avoid transmission of infectious agents that may cause serious diseases.
- Clean and disinfect as instructed in this manual.
- Do not unplug the cable or other connections without needing to.

### Precautions in case of change in the operation of the equipment

If the equipment has any abnormalities, check to see if the problem is related to an item listed in the "Troubleshooting" topic in this user manual.

If the problem cannot be resolved, unplug the equipment, disconnect the cables, and contact an Alliage Authorized Service Center.

	<p>The manufacturer is NOT responsible for:</p> <ul style="list-style-type: none"><li>• The equipment is used for purposes other than those for which it was designed.</li><li>• Damage caused to the equipment, operator and/or patient as a result of incorrect installation and maintenance procedures in disagreement with the operating instructions accompanying the equipment.</li><li>• Improper operation of the equipment.</li><li>• No modification to this equipment is permitted.</li></ul>
-----------------------------------------------------------------------------------	----------------------------------------------------------------------------------------------------------------------------------------------------------------------------------------------------------------------------------------------------------------------------------------------------------------------------------------------------------------------------------------------------------------------------------------------------------------------------------------------------------

### Precautions for reducing environmental impact

Alliage S/A aims to achieve an environmental policy to promote the supply of environmentally conscious medical and dental products that continuously minimize environmental impact and are more environmentally friendly to the environment and human health.

To maintain a minimal impact on the environment, please note the recommendations below:

- After installation, forward the recyclable materials to the recycling process.
- During the life cycle of the equipment, turn it off when it is not in use.

	<p>The packaging of the Dental X-Ray Machine consists of cardboard, plastic and polyethylene (PE) which are 100% recyclable materials.</p>
-----------------------------------------------------------------------------------	--------------------------------------------------------------------------------------------------------------------------------------------

Dimensions:

Coluna Móvel: 1320 x 650 x 260 mm /MASS: approximately: 3 kg

Parede: 900 x 569 x 277 mm /MASS: approximately: 2 kg

### Precautions in case of unusable equipment

To avoid environmental contamination or misuse of dental X-ray equipment, when it is unusable, it must be discarded (according to current legislation) in an appropriate place, as the materials inside can contaminate the environment.

For the European Economic Area (EEA), this product is subject to Directive 2012/19/EU, as well as the corresponding national laws. This directive requires that the product should be taken to a special garbage collection location at the end of its useful life. Applies to both the device and accessories. Contact the retailer if the final disposal of the product is required.

	<p>This equipment should not be discarded as household waste.</p>
-------------------------------------------------------------------------------------	-------------------------------------------------------------------

## SYSTEM OVERVIEW

### 3.SYSTEM OVERVIEW

#### 3.1.PRODUCT DESCRIPTION

The Dental X-Ray Equipment is a system that generates controlled X radiation emissions. This equipment has a set of photomultipliers that transform light energy into electrical and is used in conjunction with appropriate capture devices to generate intraoral radiological images in dental evaluation, diagnosis and treatment.

The human-machine interface of the equipment consists of a control panel located on the front of the product and a local trigger. The trigger is a dead-man type that if released interrupts exposure. The Dental X-Ray Machine is designed to be used in adult patients and children by trained dentists and dental technicians to produce X-ray images for diagnosis.

#### 3.2.APPLICATION SPECIFICATION

The Dental X-Ray Apparatus is indicated for the acquisition of intraoral medical images of teeth, mandible and oral structures; assists in the diagnosis of diseases, planning of surgical treatment and follow-up of noninvasive and painless therapy; it is for exclusive dental use, and should be used and handled by qualified and qualified health professionals according to the Owner's Manual.

##### 3.2.1.Operating principles

The Dental X-ray Equipment is an autonomous x-ray emitting system used for the acquisition of radiographic images. The x-ray beam passes through the patient's body, where a portion of the x-rays is absorbed or spread across the internal structures, and the rest of the x-rays are transmitted to a detector (e.g., film, digital sensor, or phosphor plate) for recording or further processing by a computer. The mechanism that provides the generation of x-ray electromagnetic waves in the equipment is an x-ray ampoule or Coolidge tube. The glass ampoule has its interior kept in vacuum and has two electrodes: a cathode and an anode. In the box, there is a filament that when crossed by an electric current generates heat. Once heated, the filament emits electrons by the thermionic effect. These electrons are accelerated towards the anode as a function of a potential difference between these electrodes. When electrons reach the anode, they suffer a sudden deceleration and their kinetic energy is mostly converted into heat and in x-rays through the Bremsstrahlung phenomenon.

##### 3.2.2.Significant physical characteristics

The mechanism that provides the generation of electromagnetic x-ray waves acts at a power of 70kV and with an anodic current of 7.0 mA, generating soft and hard x-rays. For radiology purposes, soft x-rays are not adequate and the patient's exposure to them is unnecessary. To minimize this effect, the equipment has an aluminum bulkhead in its tube, which performs a "filtering" of the radiation to which the patient is exposed.

Finally, we also have that the leakage radiation of the equipment is minimized by the yoke itself that is injected with a radiopaque material, avoiding unnecessary exposure of the user, and by a brass collimator at the exit of the tube, that will direct the radiation to the target of the examination.

### 3.2.3. User profile

The Dental X-Ray Equipment can be operated and handled by professional users in the area of qualified health, trained and familiar with the necessary precautions to avoid excessive exposure to radiation, of both genders, with the ability to read and understand images, symbols, icons, Western Arabic characters (Arial font), alpha numeric characters, know how to distinguish intraoral part of the human body, and may not present a degree of visual imperfection for reading or vision and average degree of impairment of recent memory, not being in clear capacity to perform the activities and functions of the product in the correct manner the profession.

### 3.3.MAIN COMPONENTS OF THE PRODUCT

**Spectro 70X Coluna Móvel**

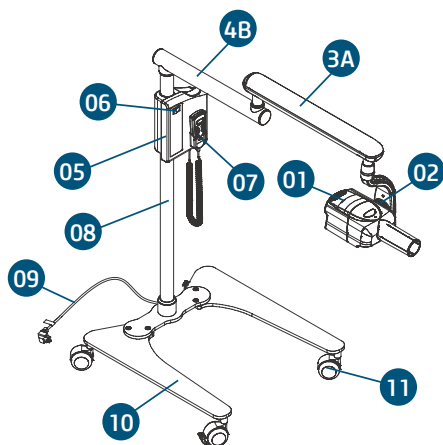

**Spectro 70X+ Coluna Móvel**

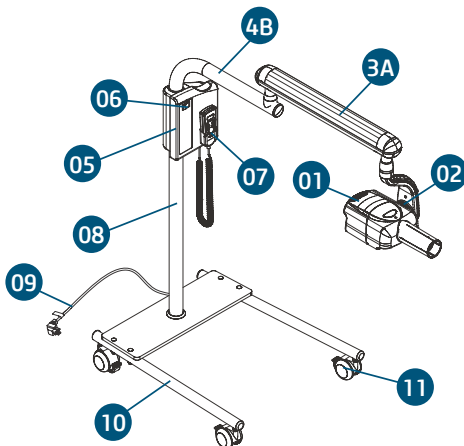

**Spectro 70X Pantográfico Coluna Móvel**

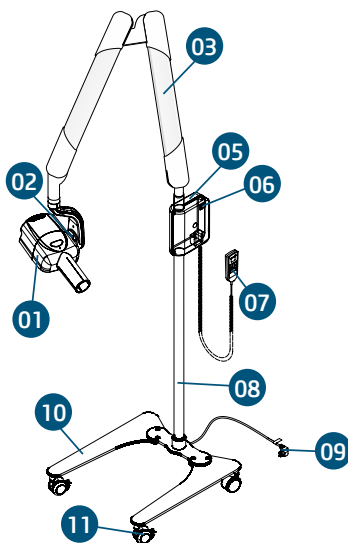

**Spectro 70X Pantográfico Parede**

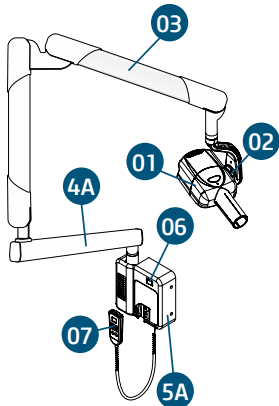

**Spectro 70X Parede**

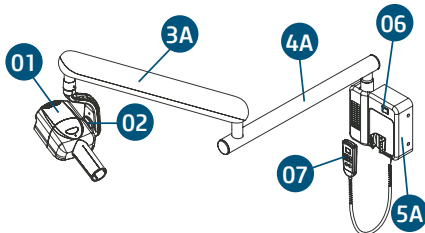

- 01. Set of X-radiation emitter (yoke)
- 02. Graduated scale
- 03. Pantographic arm
- 3A. Articulated arm
- 4A. Fixed arm (wall type)
- 4B. Fixed arm (mobile type)
- 05. Command box

- 5A. Commando box (wall type)
- 06. General key
- 07. Remote control
- 08. Column
- 09. Power input cable
- 10. Base (mobile type)
- 11. Caster

**3.4.SETS AND ACCESSORIES**



All parts described in the owner's manual are for exclusive use. The use of any parts, accessories or materials not specified in this manual is the sole responsibility of the user.

**PARTS ACCOMPANYING THE PRODUCT**

All parts described above accompany the product according to the chosen model.

**ACCESSORIES**

These products do not have accessories.

**3.5.PARTS APPLIED**

The following items may eventually contact the patient during the operation of the equipment and therefore should be treated as applied parts.

Applied part	Type of parts	Type of contact	Contact duration
Positioning cone plastic covers	Fixed	Skin	<10s

### 3.6.USER INTERFACE

#### 3.6.1.Interface Display



Icon	Function
Time	Shooting time

#### 3.6.2.Control Panel

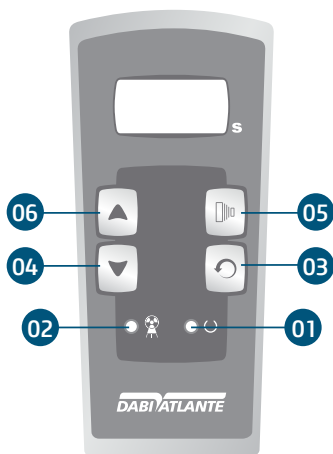

Buttons	function
1 Green LED	Indicates that the equipment is ready to operate
2 Yellow LED	Ionizing radiation emission
3 Restart	Changes x-ray emission time to zero
4 Decrease	Reduces exposure time
5 Trigger	Trigger
6 Increase	Increases exposure time



## 3.7.POSITIONING OF LABELS

The following figure illustrates the location of the labels on the equipment.

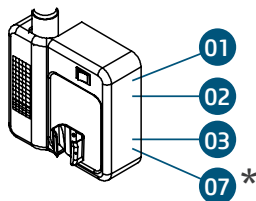
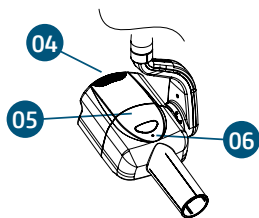

DEMONSTRATIVE IMAGE

\* Only for mobile equipment

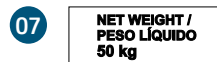
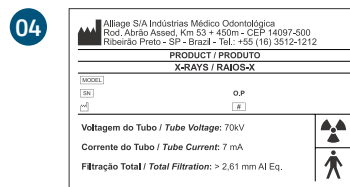
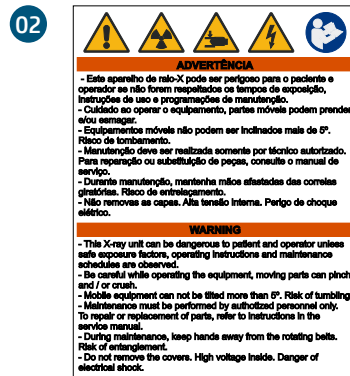
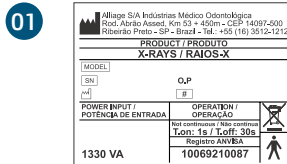

# 4

## OPERATION

## 4. OPERATION

### 4.1. INITIAL PREPARATION



The equipment should be cleaned and disinfected prior to use in a new patient, observing the instructions contained in this manual.



To insulate the power supply equipment, use the general switch.

To turn the equipment on or off use the general key located on the front of the cabinet attached to the product.

When the general key is activated, the control for exposure time selection and x radiation firing will light up, getting fit for use.

### 4.2. POSITIONING

#### 4.2.1. Preparing the patient



Ask the patient to remove any objects such as glasses, hearing aids, prostheses and personal jewelry, such as earrings, necklaces and hair clips, etc.



Ask the patient to wear the protective apron over the body, especially for pediatric patients, according to local legislation.



### 4.2.2. Positioning the patient

Proper patient positioning ensures better radiographic image quality, to do so, follow the steps below. Ask the patient to sit in a chair. Bring the emitter closer to the region to be held the exhibition.



Position the cone in the exposure area you want to x-ray.

### 4.2.3. Radiographic techniques

#### Parallelism technique or Long Cone

In this technique, the receiver is positioned parallel to the plane of the tooth shaft with the help of a positioner and the focal point of the x-ray generator should be positioned at a distance of approximately 40cm from the receiver.

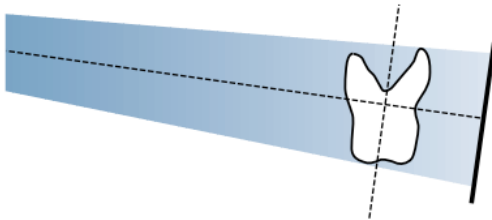

This technique that produces radiographs with minimal distortion showing the objects being x-rayed in their true anatomical relationship and size.

#### Bisector technique or Short Cone



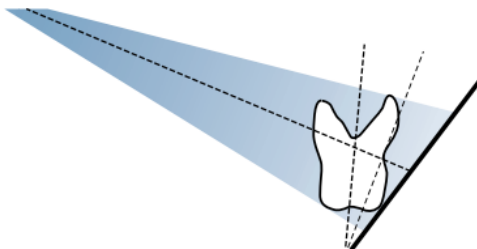

In this technique, the receiver is positioned so that the central X-ray beam must focus perpendicular to an imaginary plane of the bisector of the angle formed between the long axis of the tooth and the sensor capture surface, according to Cieszynski's isometric law. For this, the focal point of the x-ray generator must be positioned at approximately 20cm from the receiver.

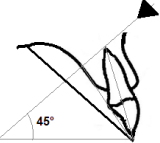

This technique that produces radiographs with distortions, regardless of the technique and accuracy of the operated, however, also provides a relatively simple, fast and comfortable positioning for the patient.

## X-Rays Spectro 70X

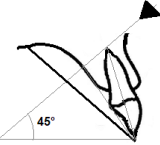
The table below indicates specific angles and directions for the x-ray beam to obtain the best images of a particular tooth using the bisector technique.

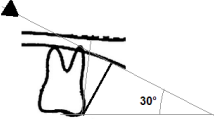
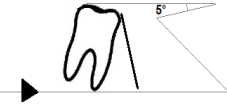
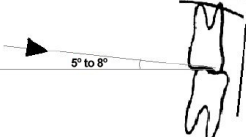
Tooth	x-ray beam tilt angle	Representation
Maxillary incisor	Directed down to 45°.	
Mandibular Incisor	Directed up to 25°	
Maxillary canine	Directed down to 45°.	
Canine Mandibular	Directed up to 20°	
Molar and maxillary premolar	Directed down to 30°.	
Mandibular molar and premolar	Directed up to 5°.	
Bitewing	Directed down to 5° to 8° and the patient closes his teeth during exposure	

### 4.3.EXPOSURE TIME

#### 4.3.1.Exposure time selection

The equipment has a panel in its enclosure with reference values for exposure time according to the patient profile, x-ray tooth and receiver selected, but these values are only starting points to be replaced by more specific protocols developed by the user. The operator must manually adjust the exposure time value.

When you turn on the equipment, the display will indicate the exposure time value 0:00 s.

The operator must select the desired time according to the exam he wishes to take.

To change the exposure time, press the ▲ increment and ▼ decrement in equipment control.

To increase the speed of the time selection, simply hold down the increment or decrement key.



At the end of the desired time selection, the green LED will light up indicating that the device is ready to display.

#### 4.3.2.Reference parameters for exposure

The table below shows the exposure times indicated for each type of patient, type of tooth and receptor type. The indicated values are only starting points to be replaced by more specific protocols developed by the user.

Type of patient	Region	Exposure Time (s)		
		Digital Sensor	Phosphor Plate	Film
<b>ADULT</b>	FRONT MANDIBULAR	0.20	0.40	0.70
	CANINE MANDIBULAR	0.20	0.40	0.70
	CANINE JAW	0.20	0.40	0.70
	MOLAR MANDIBULAR	0.25	0.50	0.80
	MAXILLARY MOLAR	0.25	0.50	0.80
	INTERPROXIMAL	0.32	0.60	0.80
<b>PEDIATRIC</b>	FRONT MANDIBULAR	0.16	0.30	0.60
	CANINE MANDIBULAR	0.16	0.30	0.60
	CANINE JAW	0.16	0.30	0.60
	MOLAR MANDIBULAR	0.25	0.40	0.70
	MAXILLARY MOLAR	0.25	0.40	0.70
	INTERPROXIMAL	0.28	0.50	0.70

## 4.4.EXPOSURE

	Ask the patient to remain immobile during exposure.
	Maintain eye contact with the patient during exposure. If a problem occurs during exposure, immediately release the trigger to stop exposure.
	If the trigger button is released, exposure will stop.

### 4.4.1.Local trigger

To perform the exposure, the operator must use the local trigger.  
After selecting the desired exposure time, the green visible LED will light up indicating that the equipment is ready to expose, press and hold the trigger tightly.

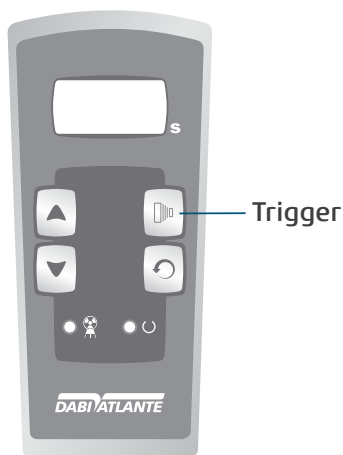

During the exposure, a yellow visible LED and a continuous audible signal will indicate the presence of X-rays.

After the x-ray exposure is over, the audible signal is interrupted and the trigger may be released. The equipment will go into cooling mode and the **"SBY"** appears on the display interspersed with the previously selected exposure time.

The equipment has an electronic system of blocking against accidental shots, avoiding consecutive shots being performed, eliminating unnecessary exposure to radiation and overheating of the emitter assembly. Thus, at the end of the shooting, the display will automatically return to the initial value zero, and it is necessary operator to select the exposure time again.

### 4.4.2.Stop firing

In the event of an emergency situation where the user interrupts the exposure by releasing the trigger, the equipment will beep alternately and the message will be displayed on the display **"A4"**.



**4.5.RECOMMENDATIONS FOR EXAMS**

Radiographs should be performed only when there is an expectation of diagnosis that may affect the patient's treatment. The dentist should weigh the benefits of obtaining x-rays against the risk of exposure to radiation from the patient.

Because of radiation buildup effect over time, every effort should be made to minimize patient exposure.

Wear lead apron and thyroid necklace.

The use of adult-designed equipment and exposure settings can result in excessive radiation exposure for smaller patients, especially pediatric patients. Pediatric patients may be more sensitive to radiation than adults (i.e., the risk of cancer per unit dose of radiation is higher) and therefore unnecessary radiation exposure is a particular concern for pediatric patients. Use pediatric profile or low dosage and select the shortest permissible exposure time.

There may be clinical circumstances for which an X-ray is indicated, but a diagnostic image cannot be obtained. For example, the patient may not be able to cooperate for the dentist.

<b>PATIENT AGE AND DENTAL DEVELOPMENTAL STAGE<sup>1</sup></b>					
<b>TYPE OF ENCOUNTER</b>	Child with Primary Dentition (prior to eruption of first permanent tooth)	Child with Transitional Dentition (after eruption of first permanent tooth)	Adolescent with Permanent Dentition (prior to eruption of third molars)	Adult, Dentate or Partially Edentulous	Adult, Edentulous
New Patient* being evaluated for oral diseases	Individualized radiographic exam consisting of selected periapical/occlusal views and/or posterior bitewings if proximal surfaces cannot be visualized or probed. Patients without evidence of disease and with open proximal contacts may not require a radiographic	Individualized radiographic exam consisting of posterior bitewings with panoramic exam or posterior bitewings and selected periapical images.	Individualized radiographic exam consisting of posterior bitewings with panoramic exam or posterior bitewings and selected periapical images. A full mouth intraoral radiographic exam is preferred when the patient has clinical evidence of generalized oral disease or a history of extensive dental treatment.		Individualized radiographic exam, based on clinical signs and symptoms.
Recall Patient* with clinical caries or at increased risk for caries**	Posterior bitewing exam at 6-12 month intervals if proximal surfaces cannot be examined visually or with a probe		Posterior bitewing exam at 6-18 month intervals		Not applicable



## X-Rays Spectro 70X

<p>Recall Patient* with no clinical caries and not at increased risk for caries**</p>	<p>Posterior bitewing exam at 12-24 month intervals if proximal surfaces cannot be examined visually or with a probe</p>	<p>Posterior bitewing exam at 18-36 month intervals</p>	<p>Posterior bitewing exam at 24-36 month intervals</p>	<p>Not applicable</p>
<p>Recall Patient* with periodontal disease</p>	<p>Clinical judgment as to the need for and type of radiographic images for the evaluation of periodontal disease. Imaging may consist of, but is not limited to, selected bitewing and/or periapical images of areas where periodontal disease (other than nonspecific gingivitis) can be demonstrated clinically.</p>			<p>Not applicable</p>
<p>Patient (New and Recall) for monitoring of dentofacial growth and development, and/or assessment of dental/skeletal relationships</p>	<p>Clinical judgment as to need for and type of radiographic images for evaluation and/or monitoring of dentofacial growth and development or assessment of dental and skeletal relationships</p>	<p>Clinical judgment as to need for and type of radiographic images for evaluation and/or monitoring of dentofacial growth and development, or assessment of dental and skeletal relationships. Panoramic or periapical exam to assess developing third molars</p>	<p>Usually not indicated for monitoring of growth and development. Clinical judgment as to the need for and type of radiographic image for evaluation of dental and skeletal relationships.</p>	
<p>Patient with other circumstances including, but not limited to, proposed or existing implants, other dental and craniofacial pathoses, restorative/endodontic needs, treated periodontal disease and caries remineralization</p>	<p>Clinical judgment as to need for and type of radiographic images for evaluation and/or monitoring of these conditions</p>			



These recommendations are subject to clinical judgment and may not apply to every patient. It is the dentist's responsibility to follow the ALARA principle (As Low As Reasonably Achievable) to minimize the patient's exposure.

\* Clinical situations for which radiographs may be indicated include, but are not limited to:

### **A. Positive Historical Findings**

01. Previous periodontal or endodontic treatment
02. History of pain or trauma
03. Familial history of dental anomalies
04. Postoperative evaluation of healing
05. Remineralization monitoring
06. Presence of implants, previous implant-related pathosis or evaluation for implant placement

### **B. Positive Clinical Signs/Symptoms**

01. Clinical evidence of periodontal disease
02. Large or deep restorations
03. Deep carious lesions
04. Malposed or clinically impacted teeth
05. Swelling
06. Evidence of dental/facial trauma
07. Mobility of teeth
08. Sinus tract ("fistula")
09. Clinically suspected sinus pathosis
10. Growth abnormalities
11. Oral involvement in known or suspected systemic disease
12. Positive neurologic findings in the head and neck
13. Evidence of foreign objects
14. Pain and/or dysfunction of the temporomandibular joint
15. Facial asymmetry
16. Abutment teeth for fixed or removable partial prosthesis
17. Unexplained bleeding
18. Unexplained sensitivity of teeth
19. Unusual eruption, spacing or migration of teeth
20. Unusual tooth morphology, calcification or color
21. Unexplained absence of teeth
22. Clinical tooth erosion
23. Peri-implantitis

\*\*Factors increasing risk for caries may be assessed using the ADA Caries Risk Assessment forms (0 – 6 years of age and over 6 years of age).

<sup>1</sup>U.S. Department of Health and Human Services. Dental Radiographic Examinations: Recommendations for Patient Selection and Limiting Radiation Exposure. Available at [http://www.ada.org/~media/ADA/Member%20Center/Files/Dental\\_Radiographic\\_Examinations\\_2012.ashx](http://www.ada.org/~media/ADA/Member%20Center/Files/Dental_Radiographic_Examinations_2012.ashx). Accessed November 2, 2015.

<sup>2</sup>The American Academy of Pediatric Dentistry. Guideline on Prescribing Dental Radiographs for Infants, Children, Adolescents, and Persons with Special Health Care Needs. Available at [http://www.aapd.org/media/policies\\_guidelines/e\\_radiographs.pdf](http://www.aapd.org/media/policies_guidelines/e_radiographs.pdf). Accessed November 2, 2015.

<sup>3</sup>U.S. Department of Health and Human Services. Pediatric X-ray Imaging. Available at <http://www.fda.gov/Radiation-EmittingProducts/RadiationEmittingProductsandProcedures/MedicalImaging/ucm298899.htm>. Accessed November 2, 2015.

# 5

## DOSE INFORMATION

### 5.DOSE INFORMATION

#### 5.1.DOSE CALCULATION

For time values selected by the operator, Kerma indications in the air at a distance of 20 cm from the focal point can be estimated using the following calculation:

$$K_{air} = 2.88 * time$$

The radiation dose was measured using a specific ionization chamber for such method that complies with IEC 60580:2019 standard for the radiation quality of the product, mounted juxtaposed to the radiation emitter, dispensing the use of a test object representative of an average patient. The formula below allows to calculate the "Dose-Area Product" (DAP) for all exposure times. The "Dose-Area Product" (DAP) measurement is calculated considering that the size of the output field at the end of the collimator cone at 20 cm from the focal point is 6 cm.

$$DAP = K_{air} * \pi * \left(\frac{6 \text{ cm}}{2}\right)^2$$

where DAP is given in mGy.cm<sup>2</sup>

## Owner's Manual

Based on the above equations and experimental measurements performed, the table below was elaborated with some dose values.

kV	mA	Exposure time (s) (Irradiation time (s))	Kerma in the air (mGy) @20cm	DAP (mGy.cm2)
70	7.0	0.06	0.132	3.732
		0.10	0.219	6.192
		0.16	0.428	12.101
		0.20	0.557	15.749
		0.25	0.728	20.584
		0.32	0.969	27.398
		0.40	1.295	36.615
		0.50	1.667	47.133
		0.56	1.909	53.976
		0.63	2.096	59.263
		0.71	2.410	68.141
		0.80	2.751	77.783
		1.00	3.563	100.741
		1.25	4.482	126.726
		1.40	4.984	140.919
		1.60	5.697	161.079
		2.00	7.988	225.855
2.50	8.920	252.207		
2.80	10.070	284.723		
3.20	11.660	329.679		

Please use this information as a reference only. If necessary, change the values according to your needs.

Note: The irradiation times defined above follow a sequence of variation of approximately 0.05 s as a reference for air Kerma doses, according to the values possible by the R'20 series of NBR IEC 60601-1-3, which can be changed to other times.



Air-based DAP and Kerma values may vary due to measurement errors as well as system and instrument variations. To compensate for such errors, a tolerance of 50% must be taken into account.

## 5.2.LEAKAGE RADIATION

In the charging state, the Kerma in the air due to the leakage radiation of the equipment, 1 m from the focal point, measured in an area of 100 cm<sup>2</sup> of which no main linear dimension exceeds 20 cm, when operated under normal load conditions, does not exceed 0.25 mGy in one hour according to IEC 60601-2-65.



Kerma values in the air may vary due to measurement errors as well as system and instrument variations. To compensate for such errors, a tolerance of 50% must be taken into account.

### LEAKAGE RADIATION

### PERMISSIVE RANGE

70 kVp, 7.0 mA (Maximum Exposure Condition)  
1 m distance to focal point  
Working cycle 1:30

< 0.25 mGy/h @1m

The following exposure tables were established in a unit equipped with a cone corresponding to a focus distance for the skin of 200 mm. The leakage doses were measured with a buffer with 2.5 mm of lead thickness. The analyzed data is shown in the table below.

DIRECTION	TEST RESULT	
	Horizontal Plane	Vertical Plane
	[mGy/h]	[mGy/h]
0°	0.0246	0.07744
30°	0.0282	0.04147
60°	0.0227	0.02462
90°	0.1908	0.03013
120°	0.0000	0.01685
150°	0.0000	0.04342
180°	0.0000	0.05087
210°	0.0000	0.02462
240°	0.0379	0.00551
270°	0.1869	0.09072
300°	0.0379	0.03208
330°	0.0360	0.06221

Light bulb voltage: 70kV  
Anodic light bulb chain: 7.0 mA  
Exposure time: 1.0s

Measuring device: Ionization chamber  
Radcal Corporation Model 9010 - SN: 5001383  
Method: Measurements around the X-ray dome.  
Accuracy of radiation output: ±4% of reading.

## 5.3. DIFFUSION RADIATION

The following exposure steps were established with a unit equipped with a cone corresponding to a focus distance for the skin of 200 mm, respectively.

### Method

The phantom skull was positioned 300 mm away from the focal point (with device indicated in position), in the maximum exposure condition.

Measurement points: 1.0, 1.5 and 2.0 m of the phantom skull.

Below the results found:

**Note:** N/D means that the value was not detected at that point.

## SCATTERING RADIATION – HORIZONTAL PLANE

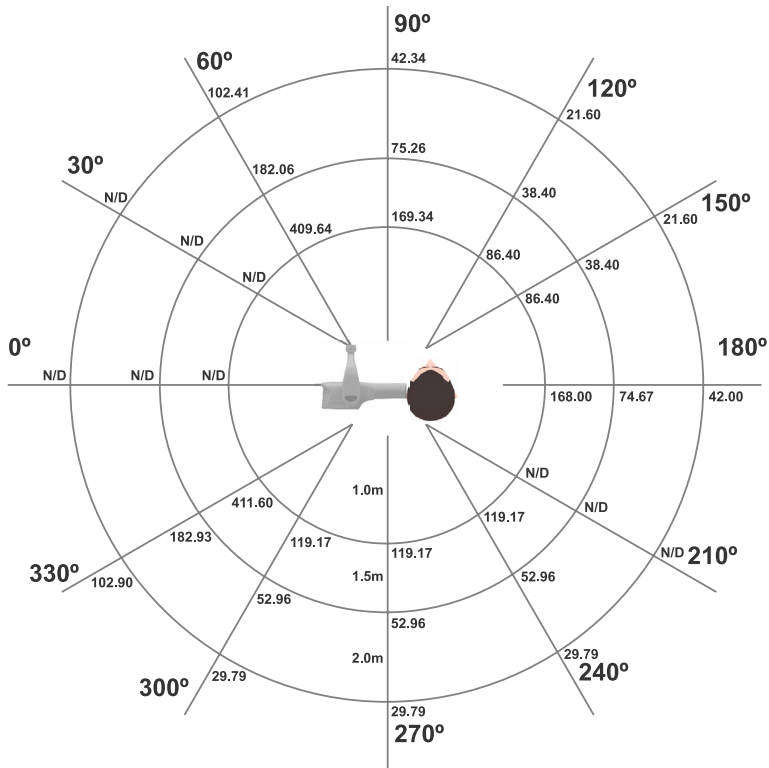

Measuring unit: nGy  
Light bulb voltage: 70kV  
Anodic light bulb chain: 7.0 mA  
Exposure time: 1.0s

Measuring device: Ionization chamber  
Radcal Corporation Model 9010 - SN: 5001383  
Method: Measurement of elevation at the level of the phantom skull in each position during the duration of exposure.  
Accuracy of radiation output:  $\pm 4\%$  of the reading.

SPREADING RADIATION - VERTICAL PLANE

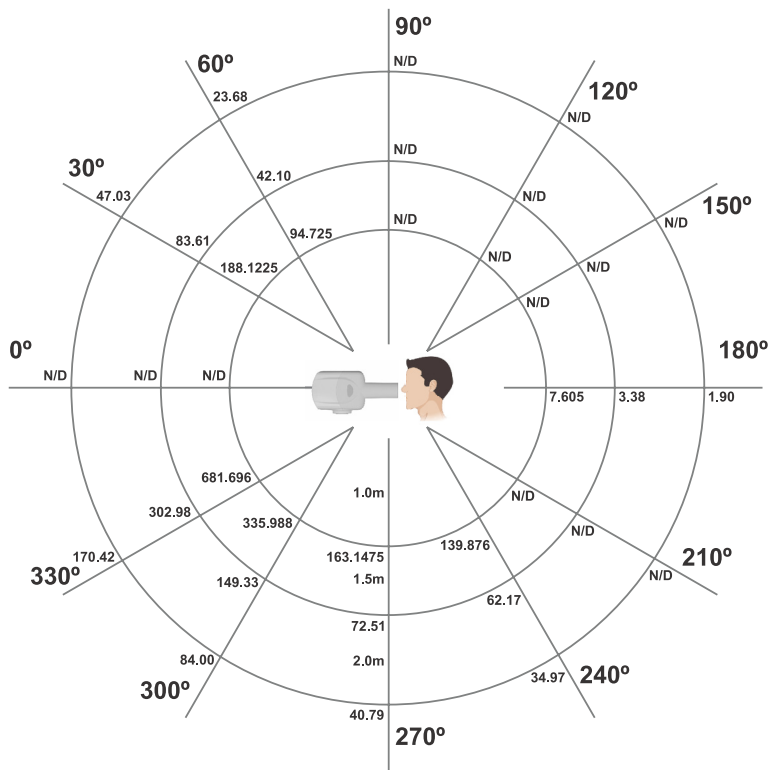

Measuring unit: nGy  
 Light bulb voltage: 70kV  
 Anodic light bulb chain: 7.0 mA  
 Exposure time: 1.0s

Measuring device: Ionization chamber  
 Radcal Corporation Model 9010 - SN: 5001383  
 Method: Measurement of elevation at the level of the phantom skull in each position during the duration of exposure.  
 Accuracy of radiation output: ±4% of the reading.



Diffusion radiation measurements are highly dependent on environmental conditions, such as the composition of the walls and their locations. Thus, under certain circumstances, the values may be significantly different.



# 6

## CLEANING AND DISINFECTION

## 6.CLEANING AND DISINFECTION



Before starting the cleaning and disinfection procedure, turn off the equipment general key to prevent permanent damage.



For your protection, during the process of cleaning and disinfecting the equipment, use PPEs as disposable gloves and goggles.

The cleaning and disinfection process should be performed at each patient change. When starting the process, check for visible dirt, such as blood or saliva on the outside of the equipment.

For the cleaning and disinfection process, the applicable parameters below should be followed. For cleaning use a clean, soft cloth dampened with mild soap and then dry with a clean, soft cloth. For the disinfection process, use disinfectant towels that have active components based on Dodecyl methylammonium chloride respecting the contact time indicated by the manufacturer. After application, allow to dry. Do not rinse.

There is no limit of cycles or application time that the Dental X-ray Equipment and its parts can tolerate during the cleaning and disinfection process, following the instructions in this manual.



Do not spill liquid disinfectant on the equipment or use spray cleaning agents.



Do not use organic solvents, e.g. thinner, to clean the equipment. In the event that the revelation solution is spilled on the panel, clean it immediately, as these solutions may compromise the equipment's paintwork.

# 7

## DIAGNOSIS OF PROBLEMS

## 7.PROBLEM DIAGNOSIS

### 7.1.ERROR MESSAGE

Occasionally, malfunction may occur during use. In the event of an error or unforeseen event, look for the following solutions.

If the problem persists, write down the error displayed and contact the authorized technical service.

Error code	Cause	Action
- A1	- Invalid network voltage: network voltage above the limit supported by the equipment.	- Check the electric network voltage.
- A2	- Invalid network voltage: network voltage below the limit supported by the equipment.	- Check the electric network voltage.
- A3/A5	- Electronic circuit failure.	- Turn the equipment off and on. If the failure persists, request the presence of an authorized technician.
- A4	- Exposure error: trigger button was released before the shot was finished.	- Redo the exposure and hold down the trigger button until the end of the exam.
- Sb	- Excessive tube heating protection.	- Wait for the correct cooling time for the return of normal functions.

### 7.2.TROUBLESHOOTING

Unforeseen	Probable cause	Solutions
- Dead completely.	- Damaged fuse.  - Lack of electricity.	- Unplug the equipment and request the presence of a technician. - Check the electrical network.
- A semi-circle appears in the radiography.	- Error in cylinder positioning.	- Radiograph using the parallelism technique, using for this the auxiliary lines of the collimator cylinder.
- Totally dark radiography.	- RX time overflow.  - Revelation. - Revelator with inadequate temperature.  - Revelator with inadequate mixing.	- Check that the time is well adjusted according to the table of radiographic techniques. - Check the reveal time. - The action of the revelator is faster the higher the solution temperature. - Redo the mixture Note: Kodak revelator does not apply mixing.
- Radiography with a dark stripe.	- Light-penetrating developing chamber.	- Avoid light input.

# 8

## QUALITY DIAGNOSIS

## 8.QUALITY DIAGNOSIS

This section will occasionally use the procedures described in the previous sections. Please refer to these sections when necessary.

During installation or after a repair, this quality control procedure will create baseline performance data.

Make a periodic evaluation and compare with baseline data.

If degradation in image quality or a change in values is noticed, contact the Alliage Service Department.

### 8.1.QUALITY CONTROL

#### 8.1.1.Accuracy

The Dental X-Ray Equipment is calibrated and tested at the factory prior to release and there are no adjustment options. However, the checks listed below must be performed by a qualified technician. Set up a performance measurer calibrated to manufacturer specifications to detect and report the following: X-ray tube voltage (kVp mean and kV PPV), Irradiation time (ms Effective mode) and Dose (mR Medium Mode).

Measurement method: Final performance measurements are made using a calibrated performance measurer. Exposure time is measured from the moment X-rays are detected until they are no longer detected (meaning that the 90% crossover setting is selected without timer delay).

The acceleration voltage (kV) is calculated using the average kVp and the practical peak value in kV (kV ppv). Linearity is calculated according to IEC 60601-2-65.

Enable Dental X-ray equipment and, with the cone positioned perpendicular to the test detector, make exposures to the test detector and capture the data resulting from the table below.

Compare the result with the factory release parameters (shown in the table below). For results outside of these parameters, stop use and contact the Alliage authorized service network.

Description of the test	Acceptable Limit
kVp	70kV ±10%
Time	Set time ± 5 % + 50 ms



It is necessary to respect the working cycle after each x-ray discharge to avoid overheating damage to the x-ray tube.

### 8.1.2. Image quality

To evaluate image quality, ask a qualified technician to perform an image acquisition using a test tool, specific for intraoral dental radiology. An image of the test tool should be produced to be used as a reference using an image receiver (Phosphorous Plate, Digital Sensor or Analog Sensor). The image should be stored to compare the results with previous or optimal values.

Biennially, an image of the test tool should be produced, with the same technique used to produce the reference image.

Quantitative and qualitative evaluations should be carried out based on the reference image and specifications of the test tool.

The presence of artifacts in the images should also not be observed.

### 8.1.3. Dose measurement

For periodic dose measurement, use one of specific ionization chambers for such a method that meets IEC 60580:2019 with an active area greater than 6 cm.

Position the dosimeter at the tube outlet 200 mm from the focal point and perform an all-time configurable exposure and record a radiation dose.

# 9

## INSPECTION AND MAINTENANCE



## 9.INSPECTION AND MAINTENANCE



Maintenance or service procedures may be carried out only by technical service authorized by the manufacturer.

All instructions for using the equipment as intended are provided in this user guide.

If any issues are detected and cannot be fixed with the instructions in the Troubleshooting section, contact the Alliage Service Department.

### 9.1.PERIODIC INSPECTION

It is imperative that this equipment be inspected regularly to ensure operational safety and functional reliability. This inspection should be done by personnel familiar with the necessary precautions to avoid excessive exposure to radiation, both primary and secondary. This equipment presents a protection to limit both the primary and secondary radiation produced by the X-ray beam, however, this protection cannot prevent carelessness, negligence or lack of knowledge.

Periodic inspection should be carried out at regular intervals (at least once a year) to ensure that the product is permanently safe and operational. All components subject to normal wear and tear should be checked and, if necessary, replaced.

The manufacturer and the assembler/installer are exempt from liability that the standard results do not conform in cases where the user does not perform the maintenance recommended by the manufacturer.

Neither inspection nor service is part of the equipment warranty.

The maintenance carried out must be documented and maintained with the equipment.

Item	Description of the inspection	Recommended frequency*
Security system	Warning and operation lights, beeps, warning labels.	Daily
Trigger	Operation	Daily
Electrical parts	Overheating/Noise/Smell of burned	Monthly
Remote control	Display/Operation/Damage	Annual
Quality <sup>1</sup>	Accuracy, Image Quality and Dose	Bienal

\* Recommendation of ICRP Agreement Publication 129



<sup>1</sup> Refer to the procedures described in Dose Measurement

If problems are detected during the inspection, please contact the Alliage Service Department.

### 9.2.PREVENTIVE MAINTENANCE

In addition to the annual inspection, to ensure a long durability and proper operation of your equipment, it is important to perform preventive maintenance in a maximum period of three (3) years. Contact the Alliage Service Department about our periodic review and preventive maintenance program.

### 9.3.CORRECTIVE MAINTENANCE

	<p>Corrective maintenance cannot be performed by the user. Do not open the equipment or attempt to repair it alone or with the help of someone without training or authorization. This can aggravate the problem or produce a failure that may compromise the safety of the equipment.</p>
	<p>The equipment or any of its parts may not receive maintenance or assistance during use with a patient.</p>
	<p>The equipment contains parts under high voltage. Risk of electric shock. Unplug it and disconnect it from the electrical network before performing technical service.</p>

Alliage declares that the provision of component lists or any other information that provides technical assistance on the part of the user, may be requested as long as previously agreed, between the user and Alliage Company.

Warranty will be void if the original parts are removed/replaced by unauthorized service technicians.

### 9.4.ALLIAGE AUTHORIZED SERVICE NETWORK

All services performed on the Alliage equipment must be performed by an Authorized Technical Assistant, as otherwise they will not be covered by the warranty.

If you need to request electrical schematics and or specification of components that are not stated in the user manual, use Alliage Customer Service to make the request.

Telephone: +55 (16) 3512-1212

Address: Rodovia Ayrão Assed, Km 53 - Recreio Anhangüera – Ribeirão Preto-SP/ Brazil CEP 14097-500

# 10

**WARRANTY**

### **10.WARRANTY**

This equipment is covered by the warranty periods, terms and conditions contained in the Warranty Certificate that comes with the product.

## TECHNICAL SPECIFICATIONS

## 11.SPECIFICATIONS AND TECHNICAL CHARACTERISTICS

### 11.1.EQUIPMENT CLASSIFICATION

EQUIPMENT CLASSIFICATION	
Framing class according to ANVISA	Class III
EQUIPMENT CLASSIFICATION ACCORDING TO THE STANDARD EN IEC 60601-1	
Product classification for applied parts	Type B
Electric Shock Protection	Class I
Internally Energized Electromedical Equipment	
Protection Against Harmful Water Penetration	IPX0 - Product not protected against harmful penetration of water and particulate matter
Degree of safety of application in the presence of a flammable anesthetic mixture with air, oxygen or nitrous oxide	Equipment not suitable
Operation Mode	Non-continuous operation Maximum exposure time: T on: 1 s / T off: 30 s

Note: The T off time is determined by multiplying Time T on by 30.

### 11.2.DEVICE INFORMATION

ITEM	DESCRIPTION
Models	<ul style="list-style-type: none"> <li>• Spectro 70X Coluna Móvel</li> <li>• Spectro 70X+ Coluna Móvel</li> <li>• Spectro 70X Parede</li> <li>• Spectro 70X Pantográfico Coluna Móvel</li> <li>• Spectro 70X Pantográfico Parede</li> </ul>
Nominal Voltage	127V/220V
Power network frequency	50/60 Hz
Permissible fluctuation	+/- 4%
Number of phases	Single phase / Biphasic
Rated current during emission	10A (max) -127V, 6A (max) -220V
Power consumption	1.33 kVA
Standby power	15 VA
Maximum network impedance	0.1 Ω
Fuse: F1/F2	F15A H 250 V (127V~) T8A H 250 V (220V~)
F3	F0.2A H 250V

ITEM	DESCRIPTION
Net weight: • Spectro 70X Coluna Móvel • Spectro 70X+ Coluna Móvel • Spectro 70X Parede • Spectro 70X Pantográfico Coluna Móvel • Spectro 70X Pantográfico Parede	50 kg 33,5 kg 25 kg 61,5 kg 31 kg
Gross weight: • Spectro 70X Coluna Móvel • Spectro 70X+ Coluna Móvel • Spectro 70X Parede • Spectro 70X Pantográfico Coluna Móvel • Spectro 70X Pantográfico Parede	53 kg 36,5 kg 27 kg 64,5 kg 33 kg
X-ray equipment for intraoral dental radiography models Spectro 70X Coluna Móvel, Spectro 70X+ Coluna Móvel, Spectro 70X Parede, Spectro 70X Pantográfico Coluna Móvel, Spectro 70X Pantográfico Parede IEC 60601-2-65:2012	

## 11.3. ENVIRONMENTAL CONDITIONS

ENVIRONMENTAL CONDITIONS OF TRANSPORT AND STORAGE	
Transport or storage temperature range	-12°C to +50°C
Transport and storage relative humidity range	20% to 90% RH
Atmospheric pressure range	500 hPa to 1060 hPa (375 mmHg at 795 mmHg)
ENVIRONMENTAL CONDITIONS OF INSTALLATION AND OPERATION	
Operating ambient temperature range	+10°C to +35°C
Operating relative humidity range (not condensed)	30% to 75% RH
Atmospheric pressure range	700 hPa to 1060 hPa (525 mmHg at 795 mmHg)
Operating altitude	≤ 2000 m

## 11.4. RADIOLOGICAL INFORMATION

GENERAL INFORMATION	
Ampoule Voltage	70kV
Ampoule Chain	7.0 mA
Maximum energy accumulated in 1 hour	170 kJ
Working factor	1 : 30
Selectable irradiation time range	0.06 a 3.2 seconds

### ACCURACY OF LOAD APPLICATION PARAMETERS

Voltage (kVp)	± 10 %
Anodic current (mA)	± 20 %
Load application time (s)	± 5 % + 50 ms
Radiation output accuracy - Beam reproducibility (CV)	± 0.05

## 11.5.X-RAY GENERATOR

### GENERAL INFORMATION

Type of generator	High voltage generator of a pulse
Maximum operating voltage (Intensity)	70 kVp
Heating and cooling curve	See graphic cooling characteristics of the head
Power at maximum output	490 W (70kV x 7.0mA)
Full filtration	> 2.61 mm Al eq. @70kVp
Permanent filtration	Glass: > 1.0 mm Al eq. @70kVp Plastic: >0.01 mm Al eq. @70kVp Insulating oil: > 0.6 mm Al eq. @70kVp Aluminum filter: >1.0 mm Al @70kVp
Leakage radiation	< 0.2 mGy/h @70kV e 7.0 mA
Target angle	16°
Focal point as specified in IEC 60336, measured in the central X-ray beam:	0.7 x 0.7 mm
Reference axis	16° in relation to the anode
Nature of radiation	Undulatory
Type of radiation	X-ray
Focus-skin distance	200 mm
Focus-receiver distance	220 mm
The X-ray generator is manufactured and assembled by Alliage S/A Indústrias Médico Odontológica.	
The Dental X-Ray Equipment has radiation protection according to ABNT NBR IEC 60601-1-3:2010	



Equipment emits ionizing radiation only when subjected to load.



Characterization of radiation X set-emitter

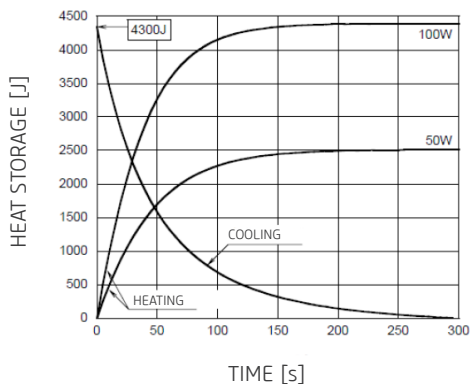

11.6.X-RAY TUBE

GENERAL INFORMATION		
Manufacturer	Canon	RADII
Model	E7696	KL27-0.8-70
Maximum operating voltage	70 kV	70 kV
Focus size	0.7 mm	0.8 mm
Angle of the anode	16°	19°
Equivalent filtering	1.0 mm Al equiv. @ 70kV	0.8 mm A equiv. @75 kV
Anode material	Tungsten	Tungsten
Anodic input power	600 W	840 W
Thermal capacity	4.3 kJ	7.0 kJ
Maximum thermal capacity and cooling curve	See graphic with thermal characteristics of the anode	See graphic with thermal characteristics of the anode
Maximum current	19 mA	23 mA
Maximum filament current	3.1 A	2.2 A
Frequency	Direct current	Direct current
Maximum continuous thermal dissipation	250 W	140 W

EMISSION AND FILAMENT CHARACTERISTICS

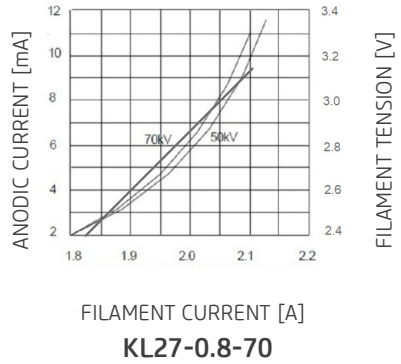
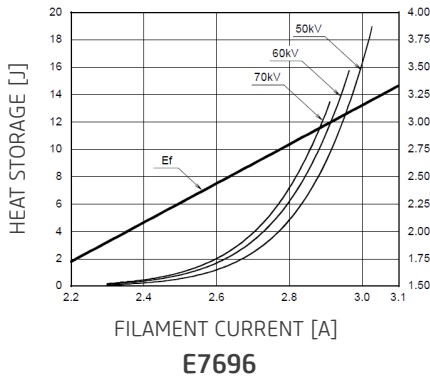

MAXIMUM LOAD CHARTS

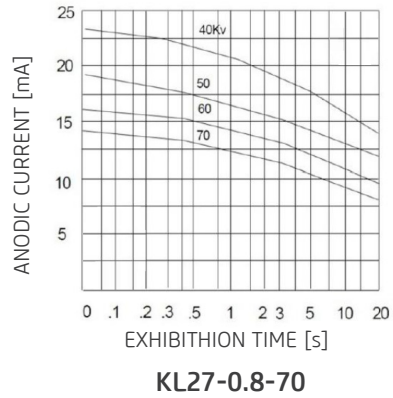
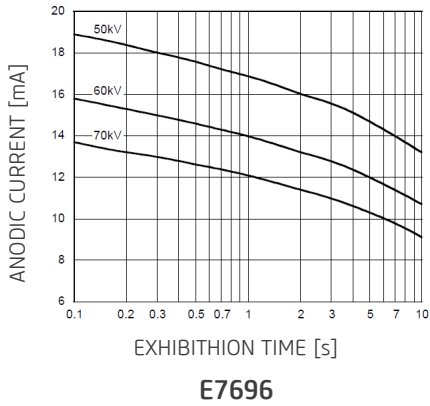

## THERMAL CHARACTERISTICS OF ANODE

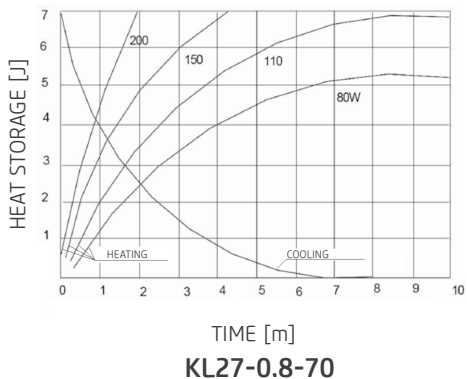
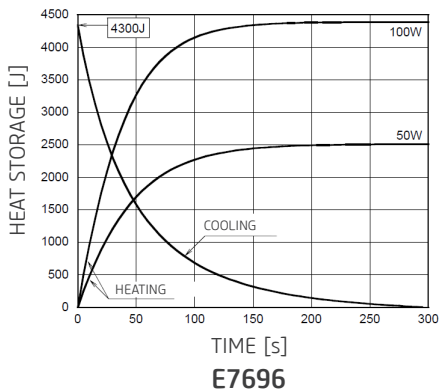

X-ray ampoules are for exclusive use of the Dental X-ray Equipment.

## BEAM LIMITER

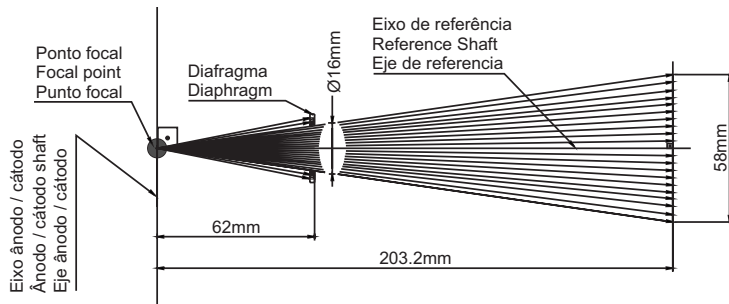

### 11.7.STANDARDS AND REGULATIONS

This equipment has been designed and manufactured to meet the following standards:

ABNT NBR IEC 60601-1:2010 Amendment 1:2016	Medical Electrical Equipment - Part 1: General requirements for basic security and essential performance.
ABNT NBR IEC 60601-1-2:2017	Medical Electrical Equipment, Part 1-2: General basic safety requirements and essential performance - Collateral standard: Electromagnetic Interference - Requirements and tests.
ABNT NBR IEC 60601-1-3:2010	Medical Electrical Equipment, Part 1-3: General basic safety requirements and essential performance - Collateral standard: Radiation protection in diagnostic X-ray equipment.
ABNT NBR IEC 60601-1-6:2011 Versão Corrigida: 2013	Medical Electrical Equipment, Part 1-6: General basic safety requirements and essential performance - Collateral standard: usability.
IEC 60601-1-9:2007+AMD1:2013	Medical electrical equipment - Part 1-9: General requirements for basic security and essential performance - Collateral standard: Requirements for environmentally conscious design
IEC 62304:2006	Medical Device Software - Software Lifecycle Processes.
ABNT NBR IEC 60601-2-65:2014	Electromedical Equipment - Part 2-65: Particular requirements for basic safety and essential performance of intraoral dental X-ray equipment.
ABNT NBR ISO 13485:2016	Quality management systems - Requirements for regulatory purposes.
ISO 10993-1:2018	Biological evaluation of medical devices - Part 1: Evaluation and testing.
ABNT NBR ISO 14971:2009	Medical devices - Application of risk management to medical devices.
IEC TR 60878:2015	Graphic symbols for electrical equipment in medical practice.

11.8.DIMENSIONAL

Model: Spectro 70X Coluna Móvel

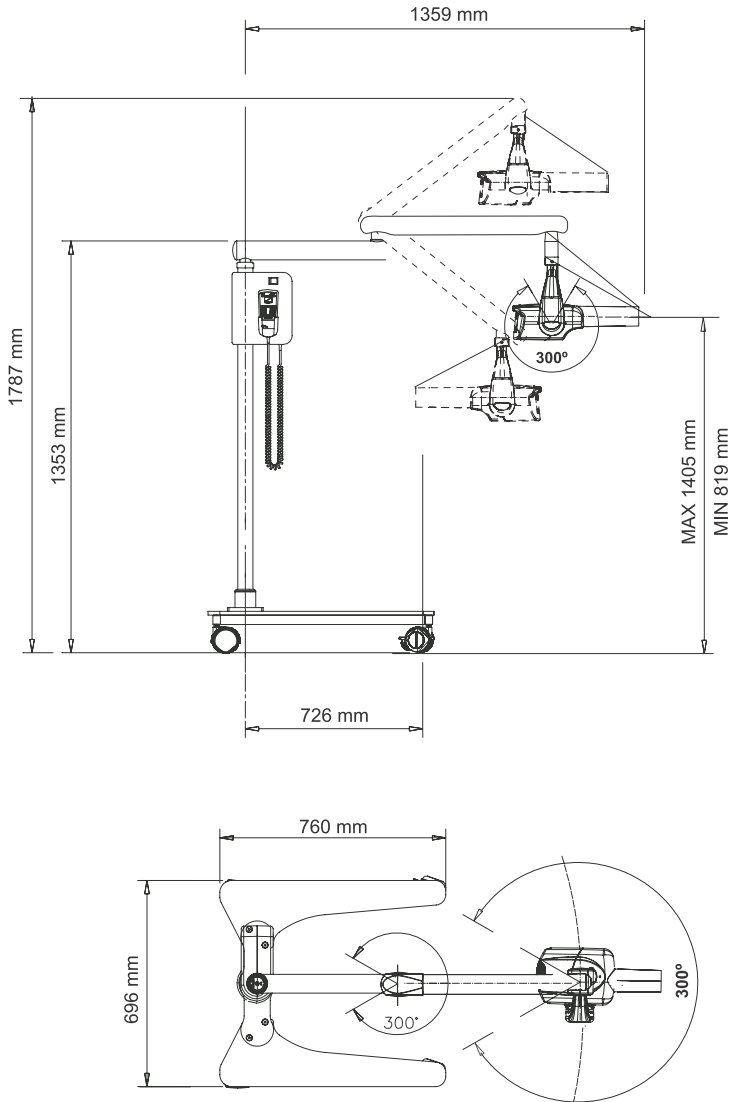

Model: Spectro 70X+ Coluna Móvel

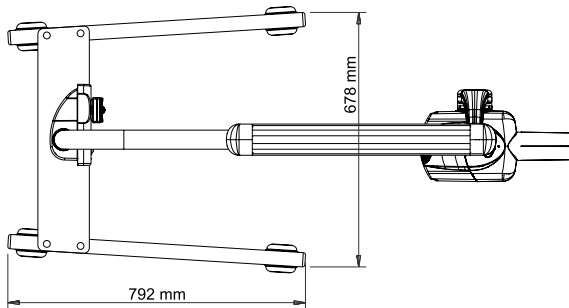
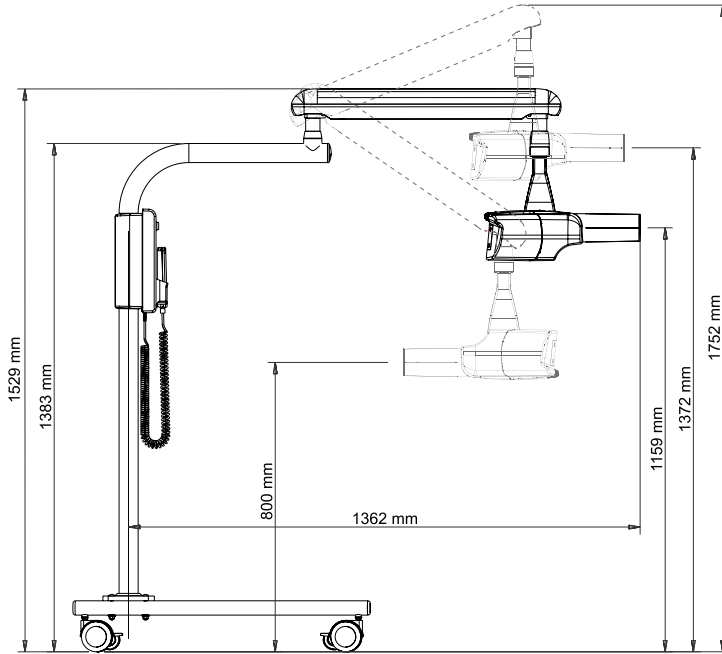

Model: Spectro 70X Parede

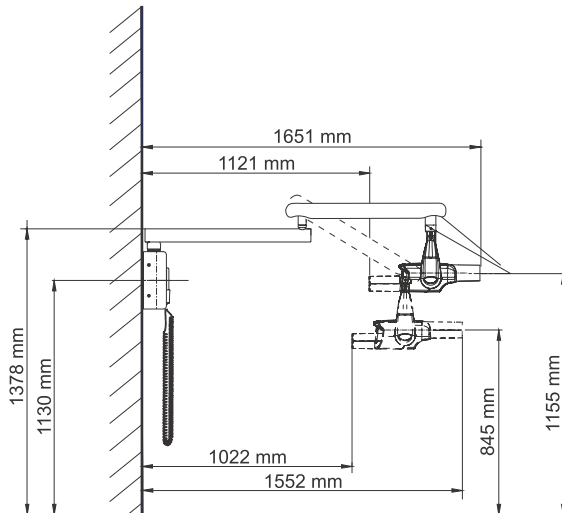
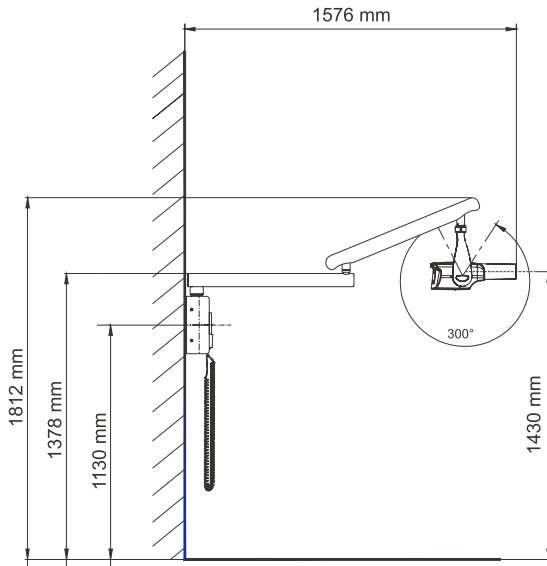

Model: Spectro 70X Pantográfico Coluna Móvel

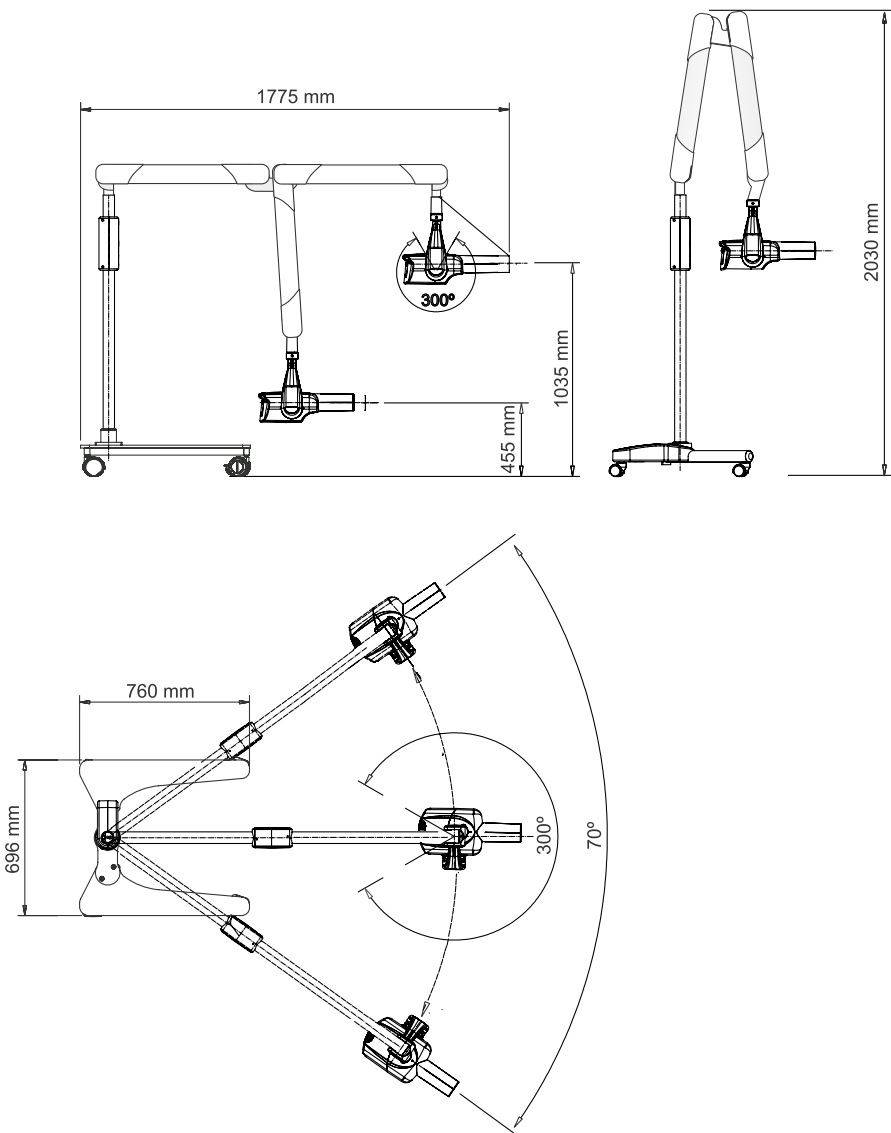



Model: Spectro 70X Pantográfico Pared

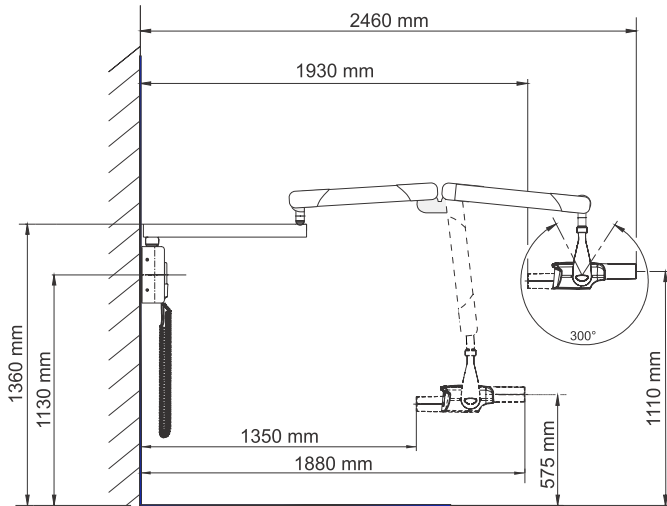
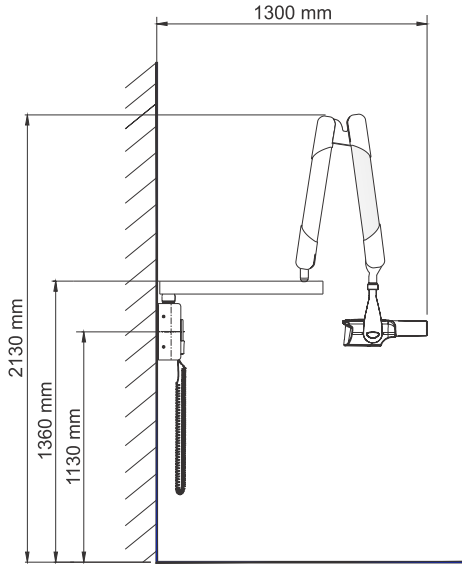

## ELECTROMAGNETIC COMPATIBILITY

## 12.ELECTROMAGNETIC COMPATIBILITY (EMC)

The Dental X-Ray Equipment is intended for use in the electromagnetic environment specified below. It is advisable that the buyer or user ensure that it is used in such an environment.

The Dental X-Ray Equipment is suitable for use in a professional healthcare environment, not including areas where there are sensitive equipment or sources of intense electromagnetic disturbances, such as the RF-shielded room of an MS system for magnetic resonance imaging, in operating rooms near active AF surgical equipment, electrophysiology laboratories, armored rooms, or areas where shortwave therapy equipment is used.

The following tables provide equipment compliance information at ABNT NBR IEC 60601-1-2:2017.

### 12.1.ORIENTATION AND DECLARATION FOR ELECTROMAGNETIC EMISSIONS

EMISSION TESTS	COMPLIANCE	ELECTROMAGNETIC ENVIRONMENTS - GUIDE-LINES
RF CISPR 11 emissions	Group 1	The Dental X-ray equipment uses RF power only for its internal functions. Therefore, its RF emissions are very low and are unlikely to cause any interference to nearby electronic equipment.
RF Emissions CISPR 11	Class A	The Dental X-ray equipment is suitable for use in all establishments, except domestic and those directly connected to the public low voltage power supply network that powers buildings used for domestic purposes.
Harmonic emissions IEC 61000-3-2	Class A	
Voltage fluctuation/ Flickering emissions 61000-3-3 IEC	In compliance	
<b>Note:</b> The emission characteristics of this equipment make it suitable for use in industrial areas and hospitals (IEC/CISPR 11, Class A). If used in a residential environment (for which IEC/CISPR 11, Class B is normally required), this equipment may not provide adequate protection for radio frequency communication services. You may need to take mitigation measures, such as relocating or reorienting the equipment.		

12.2.ORIENTATION AND DECLARATION FOR ELECTROMAGNETIC IMMUNITY

PHENOMENON	BASIC STANDARD OF EMC OR TEST METHOD	IMMUNITY TEST LEVEL	LEVEL OF CONFORMITY
Electrostatic discharge	IEC 61000-4-2	± 8 KV contact ± 2 KV, ± 4 KV, ± 8 KV, ± 15 KV air	± 8 KV contact ± 2 KV, ± 4 KV, ± 8 KV, ± 15 KV air
Radiated RF EM fields	IEC 61000-4-3	3 V / m 80 MHz - 2.7 GHz 80% AM at 1 kHz	3 V / m 80 MHz - 2.7 GHz 80% AM at 1 kHz
Proximity fields from RF wireless communications equipment	IEC 61000-4-3	See table	See table
Electrical fast transients/bursts	IEC 61000-4-4 Input a.c. power port	± 2 kV 100 kHz repetition frequency	± 2 kV 100 kHz repetition frequency
	IEC 61000-4-4 Signal input/output parts port	± 1 kV 100 kHz repetition frequency	± 1 kV 100 kHz repetition frequency
Surges Line-to-line	IEC 61000-4-5	± 0.5 kV, ± 1 kV	± 0.5 kV, ± 1 kV
Surges Line-to-ground	IEC 61000-4-5	± 0.5 kV, ± 1 kV, ± 2 kV	± 0.5 kV, ± 1 kV, ± 2 kV
Conducted disturbances induced by RF fields	IEC 61000-4-6	3 V m 0.15 MHz – 80 MHz 6 V in ISM bands Between 0.15 MHz and 80 MHz 80 % AM at 1 kHz	3 V m 0.15 MHz – 80 MHz 6 V in ISM bands Between 0.15 MHz and 80 MHz 80 % AM at 1 kHz
Rated power frequency magnetic fields	IEC 61000-4-8	30 A/m 50 Hz or 60 Hz	30 A/m 50 Hz or 60 Hz
Voltage dips	IEC 61000-4-11	0 % UT; 0.5 cycle	0 % UT; 0.5 cycle
		A 0°, 45°, 90°, 135°, 180°, 225°, 270° and 315°  0 % UT; 1 cycle and 70 % UT; 25/30 cycle Single phase: at 0°	A 0°, 45°, 90°, 135°, 180°, 225°, 270° and 315°  0 % UT; 1 cycle and 70 % UT; 25/30 cycle Single phase: at 0°

## X-Rays Spectro 70X

Voltage interruptions	IEC 61000-4-11	0 % UT; 250/300 cycle	The device will shut down and / or reset if power is interrupted for five seconds.
-----------------------	----------------	-----------------------	------------------------------------------------------------------------------------

NOTE 1 At 80 MHz and 800 MHz, the highest frequency range is applicable.

NOTE 2 These guidelines may not apply to all situations. Electromagnetic propagation is affected by the absorption and reflection of structures, objects and individuals.

NOTE 3 UT is the AC network voltage before the test level is applied.

PROXIMITY FIELDS FROM WIRELESS RF COMMUNICATIONS EQUIPMENT						
TEST FREQUENCY (MHZ)	BAND (MHZ)	SERVICE	MODULATION	MAXIMUM POWER (W)	DISTANCE (M)	IMMUNITY TEST LEVEL (V/M)
385	380-390	TETRA 400	Pulse modulation 18Hz	1.8	0.3	27
450	430-470	GMRS 460,FRS 460	FM $\pm$ 5 kHz deviation 1kHz sine	2	0.3	28
710	704-787	LTE 13, 17 Band	Pulse modulation 217 Hz	0.2	0.3	9
745						
7480						
810	800-960	GSM 800/900, TETRA 800, iDEN 820, CDMA 850, LTE 5 Band	Pulse modulation 18 Hz	2	0.3	28
870						
930						
1720	1700 -1990	GSM 1800; CDMA 1900; GSM 1900; DECT; LTE 1, 3, 4, 25 Band, UMTS	Pulse modulation 217 Hz	2	0.3	28
1845						
1970						
2450	2400-2570	Bluetooth, WLAN 802.11 b/g/n, RFID 2450, LTE 7 Band	Pulse modulation 217 Hz	2	0.3	28
5240	5100 - 5800	WLAN 802.11 a/n	Pulse modulation 217 Hz	0.2	0.3	9
5500						
5785						

LIST OF CABLES USED		
CABLES	DESCRIPTION	LENGTH
Local trigger	PVC spiral cable, circular section, 6 conductors, 100V, 70°C, polypropylene insulation.	5 m
Power input for mobile equipment	Tripolar Power Cable Gauge 3x 1.00 mm <sup>2</sup> , 250V AC, Male Plug 10A NBR 14136 2P+T, with female plug, Inmetro.	1.9 m
Power input for wall equipment	Tripolar Power Cord Gauge 3x 1.00 mm <sup>2</sup> , 250V AC.	3 m

	The Dental X-ray Equipment is intended to obtain radiological images of oral anatomy, including teeth, maxillofacial areas, oral and bone structures, and it is for dental use only. In case of MS disturbances, the operator may experience the locking of the equipment interfaces.
-----------------------------------------------------------------------------------	---------------------------------------------------------------------------------------------------------------------------------------------------------------------------------------------------------------------------------------------------------------------------------------

	Compliance with EMC and EMI standards cannot be guaranteed by the use of altered cables or cables that do not meet the same standards as the equipment has been validated.
-----------------------------------------------------------------------------------	----------------------------------------------------------------------------------------------------------------------------------------------------------------------------

	The use of this equipment adjacent to other equipment should be avoided as this may result in improper operation. If this use is necessary, it is advisable that this and other equipment be observed to verify that they are operating normally.
-----------------------------------------------------------------------------------	---------------------------------------------------------------------------------------------------------------------------------------------------------------------------------------------------------------------------------------------------

	Do not use accessories, transducers, internal parts of components and other cables other than those previously specified by the manufacturer. This may result in increased emission or decreased electromagnetic immunity result in improper operation.
------------------------------------------------------------------------------------	---------------------------------------------------------------------------------------------------------------------------------------------------------------------------------------------------------------------------------------------------------

	To maintain basic safety against electromagnetic disturbances during the expected service life, always use the equipment in the specified electromagnetic environment and follow the maintenance recommendation described in this manual.
-------------------------------------------------------------------------------------	-------------------------------------------------------------------------------------------------------------------------------------------------------------------------------------------------------------------------------------------

	Pins, connector sockets, or elements bearing the ESD warning symbol must not be touched or interconnected without ESD protection measures.
-------------------------------------------------------------------------------------	--------------------------------------------------------------------------------------------------------------------------------------------



NUM. REG. ANVISA: 10069210087

**DABI ATLANTE**

[www.dabiatlante.com.br](http://www.dabiatlante.com.br)

uma marca  
**aljiage**