

## Property facilities specifications

The knowledge of the specifications for the property facilities of the dental practice units contributes to their performance and durability. Therefore, before installing your equipment, read this manual carefully. All the information, illustrations and specifications of this manual are based on the information available at the time of publication. We reserve the right to make changes at any time, both to the product and to this Manual, without prior notification.

An authorized Alliage technician, under penalty of losing the guarantee, must carry out the installation of the dental practice units.

The design, sizing and execution of the property facilities must be carried out by specific professionals in accordance with current regulations and legislation.

The specifications contained in this manual are based on the normative guidelines of ABNT.

## Dental practice unit positioning

To achieve the best distribution of spaces for the dental practice unit, a place must be chosen such that allows the ergonomic installation of the equipment, so that the professional can obtain ideal conditions of ambience and integration to work, improving his quality and productivity. Therefore, the installation of the equipment must be carried out in accordance with the standards recommended by I.S.O. (International Organization for Standardization) and F.D.I. (International Dental Federation) For analysis of the equipment according to its location in the dental practice unit, I.S.O./F.D.I. they determined to divide the room in few areas. To demarcate these areas, idealize a clock counter, where the center is the axis of the pointers and corresponds to the mouth of the patient lying in the dental chair positioned on the horizontal.

- Around this center, draw three concentric circles, A, B and C of radius 0,5; 1,0; 1,5 meters respectively.

- The patient's head always indicate the 12-hour position. In this way, the axis 6-12 hours, divides the room into two areas: on the dental chair (area of the dentist) and below (area of the assistant).

- The area limited by circle A, 0,5 meters radius, corresponds to the Transfer Zone, where everything that is transferred to the patient's mouth must be located, as are the instruments and the manual parts of the Equipment. In this area should also be located the two bench seats, the dentist and his assistant.

- Circle B of 1,0 meter radius limits the Working Area (maximum range), which can be reached with the movement of the stretched arm. In this area should be the auxiliary tables and the body of the Equipment.

- Circle C of 1,5 meters radius limits the total area of the dental practice unit. Fixed cabinets and vats are located in this area, so when opening the drawers, they must be inside circle B.

## Compressed air

The compressed air installations must be free of solid particles, liquids and oil. Size the compressed air network between 80 to 120 PSI and install the air compressor close to the supply point to avoid losses.

Avoid installing the compressor in sanitary facilities such as bathrooms and lavatories, to minimize air pollution used in dental practice units. An air filter with pressure regulator must be installed in each dental practice units using a ¼ x 10mm elbow at the inlet and a ¼ x 6mm elbow at the outlet.

Compressed air pipes must have a slope of 5% to 10% in the direction of the air flow and an automatic drain valve at the lowest point of the pipe. In installations, preferably use 10mm Polyurethane tubes.

## Electricity

Use circuit breaker properly sized to protect the installed equipment. Separate the electrical circuits of the equipment according to their power. Install the dental practice unit, compressor, vacuum pump, x-ray and autoclave on separate circuits.

Ground all the electrical power points of the equipment.

## Water

Use only clean, potable water in the dental practice unit.

In the installations use PVC pipes.

Install the water tap for each dental practice unit.

Install water register for the Vacuum Pump

## Sewer

The drainage pipes must have a slope of 2% to 5% in the direction of the drain flow.

Use separate sections for the drainage of the vats and lavatories, the dental chair and the vacuum pump. Connect the drain sections only in a siphoned box.

In siphoned boxes use preferentially blind lid or lattice with closure. In joints use only pieces at 45° to avoid blockages and the correct direction to the drain.

Install in the drainage network, ventilation branch to avoid negative pressure inside the pipe.

Use rigid PVC pipes.

## High Power Suction

Sewer pipes of high power suction should be made with rigid PVC pipes, with 25mm diameter, joints at 45° and inclination in the flow direction. The electrical command installations of high power suction must be made in parallel when used in more than one dental practice unit.

## Technical specifications for sizing the installations

Equipment	Air consum. l/min	Water consum. l/min	Voltage (V)	Power (VA)
Dental chair	-	-	110 / 127 o 220	350
Venturi	25	-	-	-
Vac Plus	35	-	-	-
Micro motor	50	0,09	-	-
High rotation	35	0,09	-	-
Triple syringe	19	0,13	-	-
X-rays	-	-	127 ou 220	1200
½ HP Vacuum Pump	-	0,4	Bi-volt (key)	1220
1 HP Vacuum Pump	-	0,4	Bi-volt (key)	1690
12 L Autoclave	-	(see manual)	Bi-volt (key)	1600
21 L Autoclave	-	(see manual)	Bi-volt (key)	1700
40L Compressor	-	-	127 o 220	830 / 1100
65L Compressor	-	-	127 o 220	1660 / 2200
150L Compressor	-	-	220	2948



# PRE INSTALLATION MANUAL

PROPERTY FACILITIES SPECIFICATIONS FOR DENTAL PRACTICE UNITS

Consider 1560mm from point R up to point P  
 R - Intersection between point D and the central axis of the dental chair  
 P - Head support Work Point

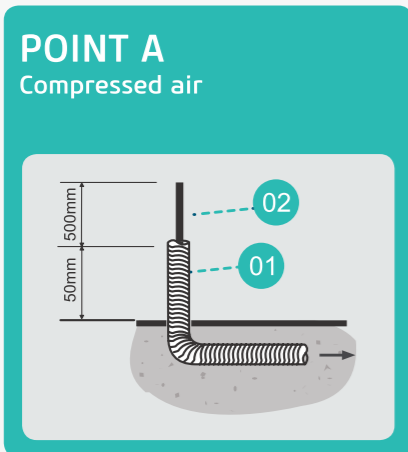
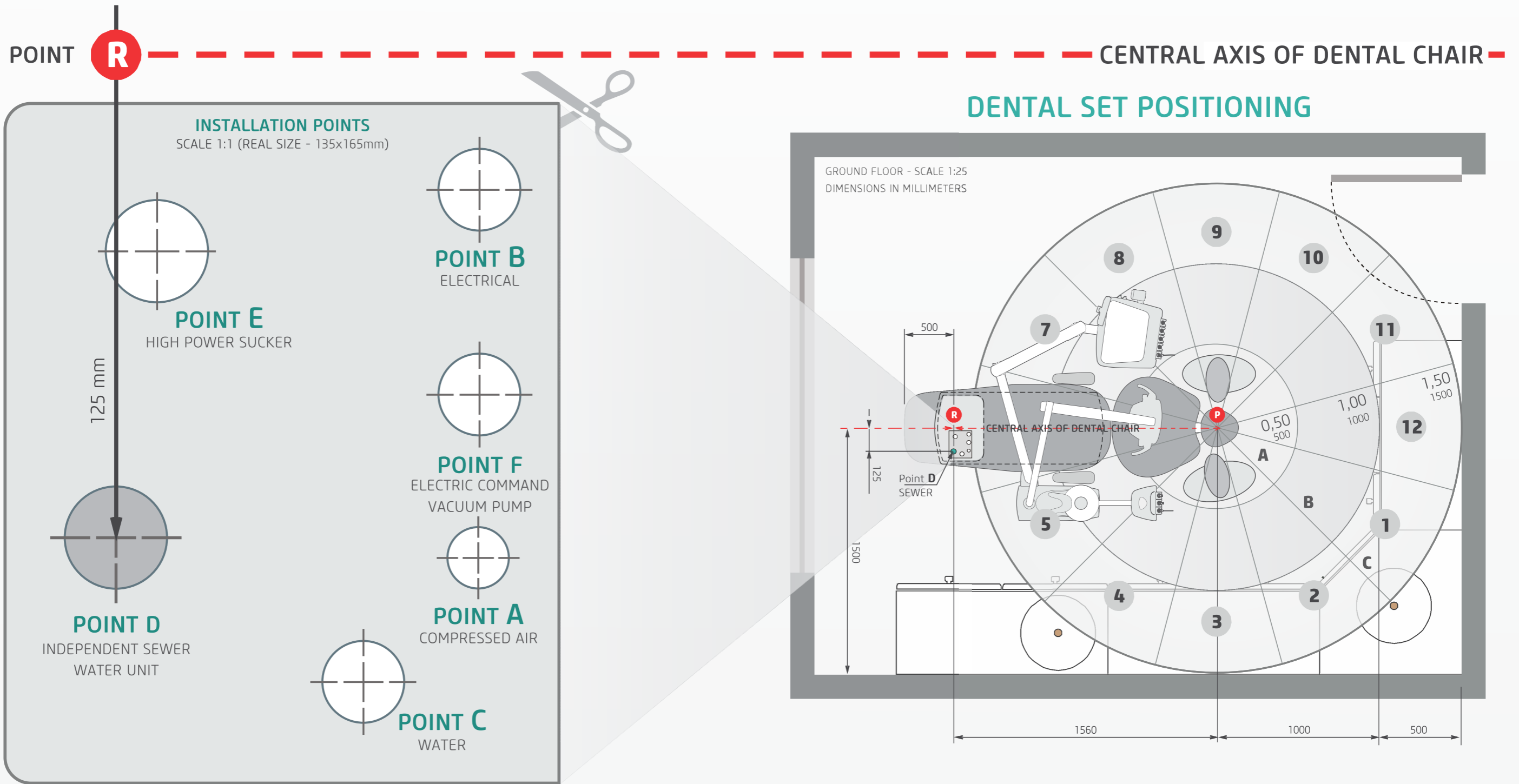

**POINT A**  
 Compressed air

↑ Air supply

01. Corrugated flexible conduit Ø20mm  
 02. 10mm Polyurethane Tube

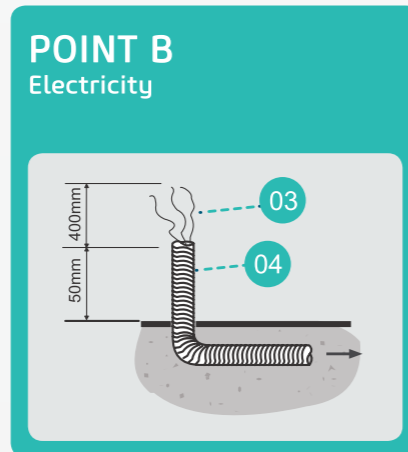

**POINT B**  
 Electricity

→ Connected to the power network

03. 3 cables 2,5mm<sup>2</sup>  
 04. Corrugated flexible conduit Ø20mm

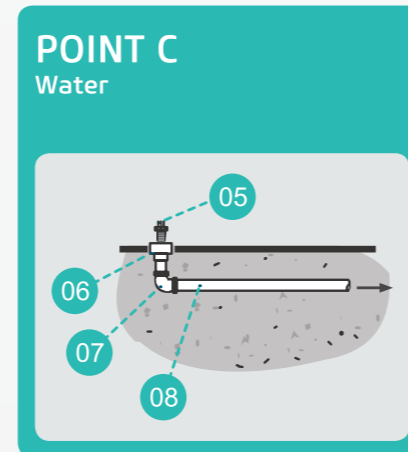

**POINT C**  
 Water

→ Connected to the water network

05. Water inlet connection Ø1/2"  
 06. Weldable nipple with brass cap Ø20mm x 1/2"  
 07. Weldable 90° elbow Ø20mm  
 08. Weldable rigid PVC tube Ø20mm

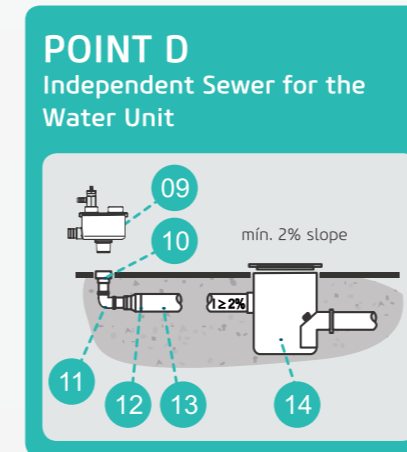

**POINT D**  
 Independent Sewer for the Water Unit

09. Buffer  
 10. Weldable nipple with brass cap Ø25mmx3/4"  
 11. Weldable 90° elbow Ø25mm  
 12. Long weldable reduction socket  
 13. Weldable rigid PVC tube Ø40mm  
 14. Siphoned box 150x150x50mm

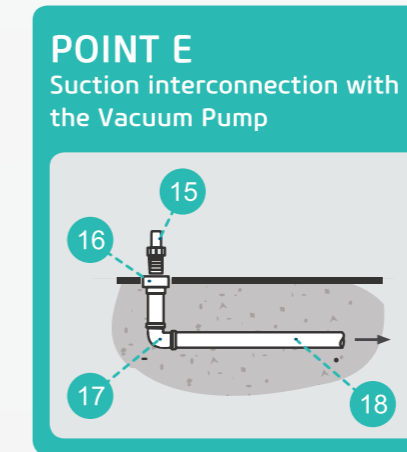

**POINT E**  
 Suction interconnection with the Vacuum Pump

→ Interconnection of points "E" connection box and Vacuum Pump

15. Hose adapter Ø3/4"  
 16. Weldable nipple with brass cap Ø25mmx3/4"  
 17. Weldable 90° elbow Ø25mm  
 18. Weldable rigid PVC tube Ø25mm

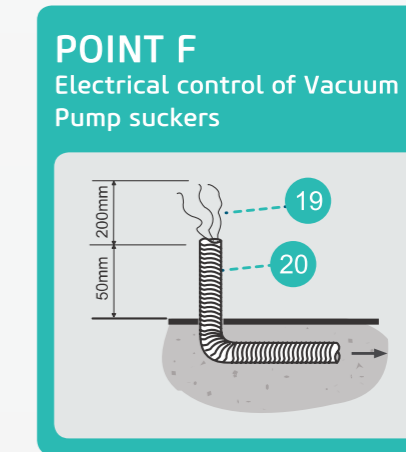

**POINT F**  
 Electrical control of Vacuum Pump suckers

→ Interconnection of points "F" connection box and Vacuum Pump

19. 3 cables 0,75mm<sup>2</sup> (different colors)  
 20. Corrugated flexible conduit Ø20mm

# SPARE CONNECTION BOX

SCALE 1:1 (REAL SIZE-402x280mm)

## ATENCIÓN

The dental practice units use an integrated connection box at the base of the dental chair. For installations with standard connection box separated from the base, it is necessary to acquire the kit for loose connection box (sold separately), in this case use this installation pattern.

DISTANCE RECOMMENDED FOR INSTALLATION WITH SPARE CONNECTIONS BOX

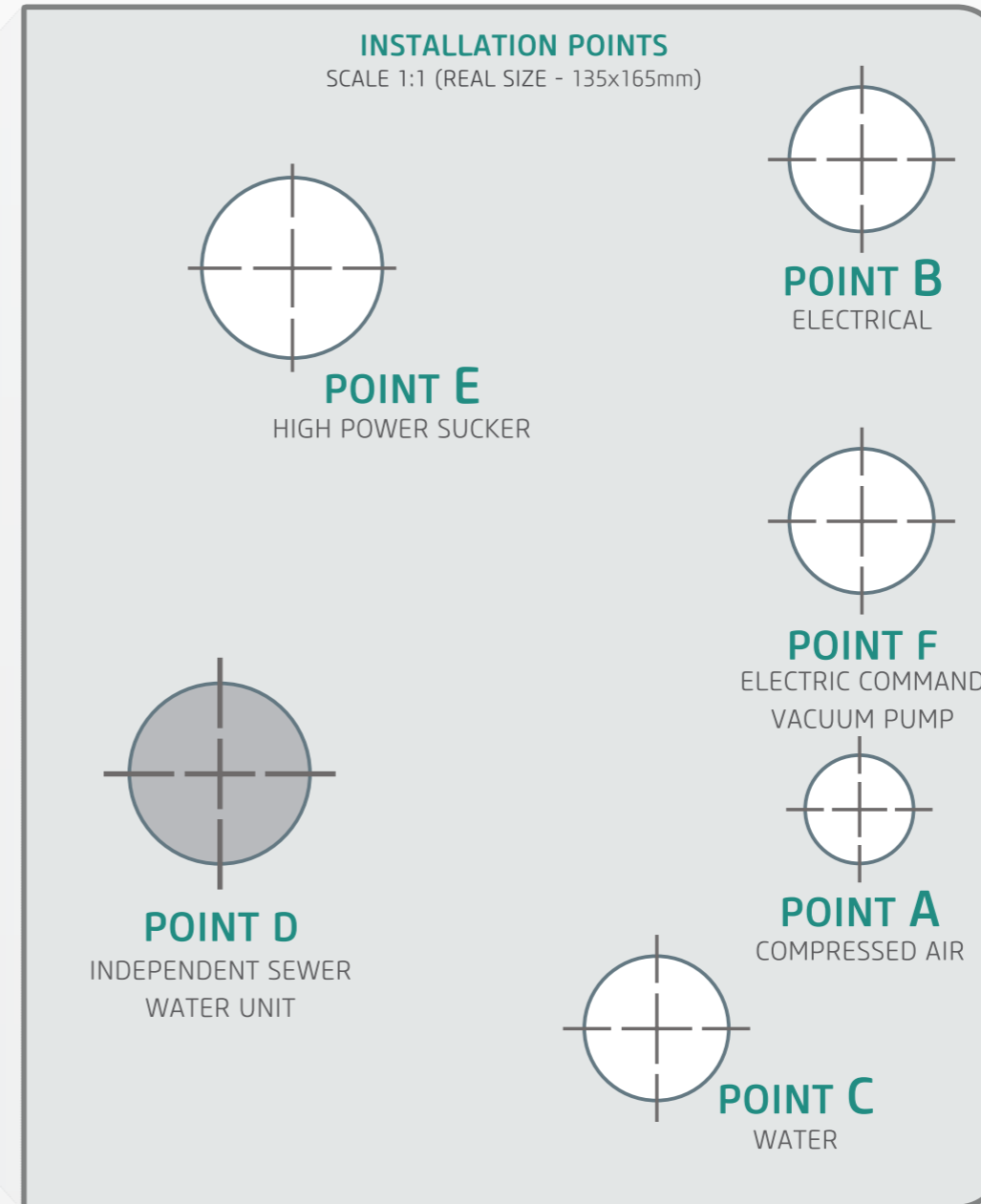
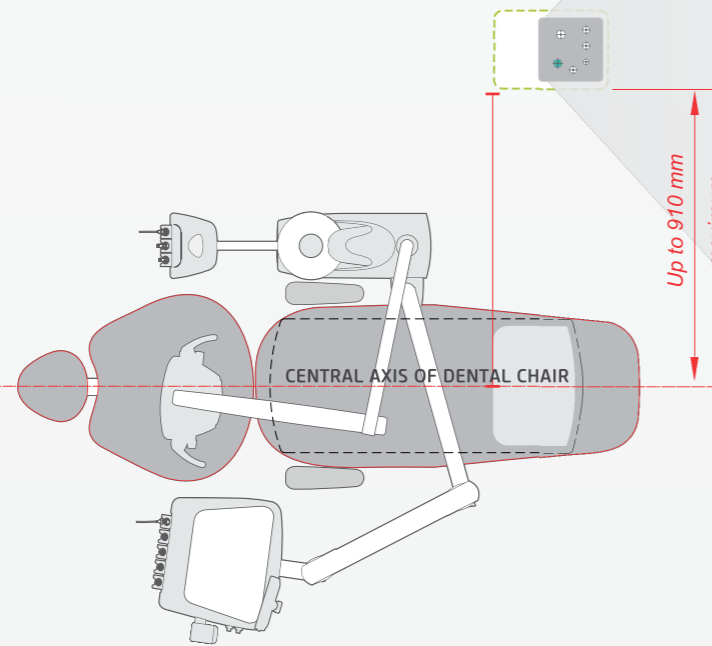

WATER UNIT OUTPUT

FLEX EQUIPMENT (AIR) AND WATER UNIT OUTPUT

FLEX EQUIPMENT OUTPUT (AIR)

PEDAL OUTPUT

CART EQUIPMENT OUTPUT